

A leader doesn't follow steps
... he marks the way

SUPER FLEXIBLE STUD 105

VF-105



Features

- * One-piece design.
- * Highly flexible and resistant material.
- * Its corners and edges are rounded in case of impact, this prevents injuries in users.
- * It's immune to the environment, corrosion, and rusting. It's also UV rays protected.
- * Ideal in turnouts of two-lane expressways and freeways.
- * It helps delimit contraflow lanes.
- * It's useful for traffic control in parking lots.
- * It adheres reflective layer.

Technical specifications

Made of: Semi-rigid polyurethane.
System: FXS-1012/2.
Mixture: Polyol-isocyanate 100/60.
Color: The base is orange. High-Intensity Grade white, yellow or red circles.
Reflective:

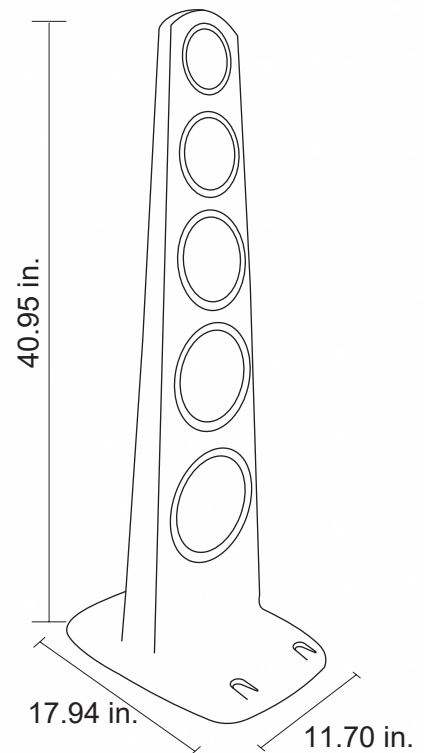

Volumes, dimensions, and other measures are nominal and may vary by approximately 2 %.