

STIMSONITE 2014 ROAD STUD

Code: C-80

A leader doesn't follow steps
... he marks the way



WHAT'S A STIMSONITE 2014 ROAD STUD?

It's a pavement marker due to its retro-reflection in the dark. A supporting element in the demarcation of roads.

It's mainly suggested in the city or on highways where there's no good visibility, especially at night, when it rains, or when it's foggy.

It serves to forecast and direct to safety areas. It's also used near dangerous zones like bridges, tunnels, slopes, or curves.

Características

- The ABS composition improves the resistance performance and expansion of the materials of the Road Stud, even in extreme temperatures. It complies with the ASTM D-4280 standard.
- High-tech design. It has the shape of a truncated pyramid.
- It doesn't affect the movement of vehicles because its height doesn't exceed 0.78 in. And the angle between the reflective and the base doesn't exceed 45°.
- The reflective with anti-abrasive coating makes it have a long working life.
- The honeycomb-shaped panels of the road stud give it the necessary bending capacity to absorb the applied vehicle compression of impacts.
- One or two retro-reflective faces according to your needs (directional or bidirectional vision).
- The color depends on your project:
White: To separate lanes that go in the same direction.
Yellow: To separate traffic flow in opposite directions.
- The side indentations facilitate its manual placement.



STIMSONITE 2014 ROAD STUD

Code: C-80

Volumes, dimensions, and other measures are nominal and may vary by approximately 2%.

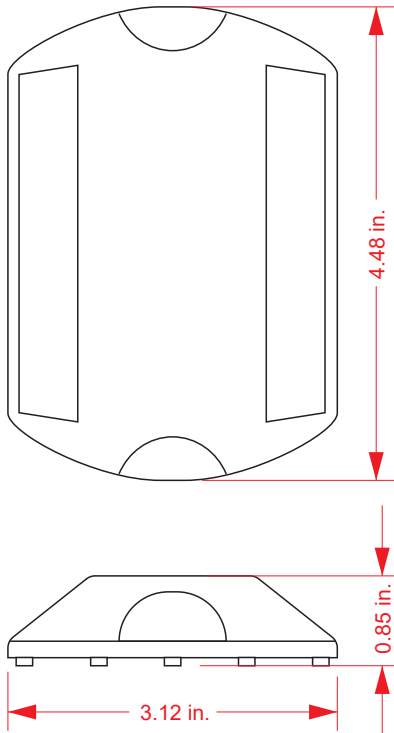

Measures:

Total	Length: 4.48 in. Width: 3.12 in. Height: 0.85 in.
Reflective:	2.56 in ² per side
Reflective color:	White or amber.
Weight:	2.62 oz

installation

The road stud installation is done by hand and mostly with epoxy glue.

1. The surface must be clean and dry. Mark the road stud distribution.
2. Apply epoxy glue on the back of the road stud. Make sure it's completely covered, especially the corners.
3. Put the road stud and press it. It doesn't matter that the glue pours out.

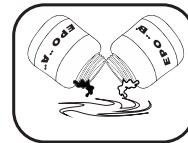
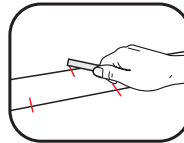

NOTE:

EPOXY GLUE PREPARATION:

MIX TOGETHER THE SAME AMOUNT OF THE "A" AND "B" FORMULAS.

STIR UNTIL YOU GET A HOMOGENEOUS MIXTURE.

ONCE YOU FINISH, GET RID OF THE REMAINING EPOXY GLUE SINCE IT'S OF ONLY USE.