

Premium Traffic Drum 117

Code: TSLP-117

We are on
the next level!

WHAT IS A TRAFFIC DRUM?

Traffic drums are road safety elements essential to improve visibility in risk zones or road works.

With cylindrical shape, these devices can be set individually and by group, depending on the place needs and the required warning level.

These are particularly useful to manage traffic flow and reduce risk of accidents by alerting to drivers and pedestrians about potential dangers in roadway, such as bumps, detours, or presence of personnel working on road.

Traffic drums have possibility to incorporate reflective rings; these can be "A or B" type, as required, improving visibility of device during night or in low light conditions, helping to be more easy to recognize dangers from a considerable distance.



Features

- In addition, the design of traffic drums transform them into clear and conspicuous tools, increasing efficacy as warning signs. Their correct use help to maintain safety in risk zones, reducing significantly the probability of accidents and enhancing traffic flow.
- Manufactured in polymer of orange, yellow, blue or green color (other color upon request) of the highest quality, guaranteeing a long durability thanks to resistance to inclemency and UV rays.
- Manufactured in a single piece with top grip, enabling an easy management; easy installation; it can be adapted to flashing light.
- Small reliefs on body that allow stacking, reducing transportation and storage costs.
- Option to include base with weight; detachable for greater stability by avoiding tilts caused by wind, manufactured in black polymer.
- Easy to clean, resistance to liquids and solvents.



Images are illustrative

Premium Traffic Drum 117

Code: TSLP-117

Dimensions and other measures are nominal and may vary by +/- 2%.

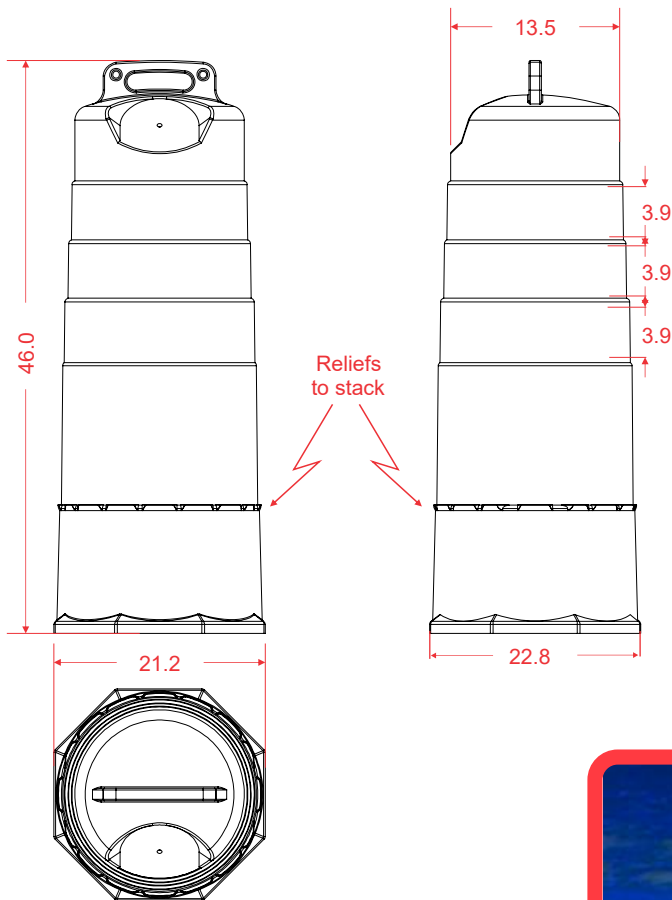

Measures

Traffic drum dimensions: Top diameter: 13.3 in
Lower diameter: 16.9 in
Height: 46.0 in

Base: Length: 22.8 in
Width: 21.2 in
Height: 1.5 in

Type "A or B" reflective mat, according to requirements: 3.9 in of height, white color (preferably)

Approx. weight of traffic drum: 5.732 lbs

Approx. weight with base: 12.345 lbs



Images are illustrative