

PARKING STOP 55

Code: TPES-N-55

A leader doesn't follow steps, **he marks the way.**



WHAT'S A PARKING STOP 55?

Useful to effectively stop vehicles when they get into a parking space.

The main function of Parking Stop 55 is guiding and delimiting vehicles when they park.

Perfect to effectively stop vehicles when they get into a parking space by helping to protect them and the structure around them.

Features

- The TPES-N-55 is more flexible and resistant. It also doesn't break or crack, unlike concrete or asphalt parking stops that need replacement.
- It adjusts to any flat surface.
- It has the perfect height to avoid potential damage to lower-height vehicles.
- The rounded edges grant it great safety without damaging vehicles.
- The material of this parking stop is a black polymeric blend in one piece that maintains its color for more time.
- 100% recycled.
- UV protection. Humidity, oil, and weather resistance.
- Perfect for indoor and outdoor parking lots.
- It includes a stripe on the side with two options:
 - Painted in traffic yellow.
 - Yellow or blue Engineer Grade Prismatic reflective.
- It has two boreholes to allow installation.
- Easy to install and remove with two 7/16" × 6½" steel nails and epoxy glue (not included).

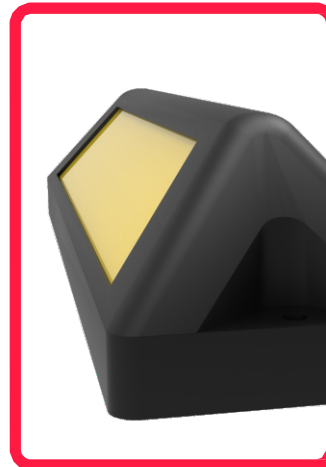

The images are merely representations of the model.

PARKING STOP 55

Code: TPES-N-55

Volumes, dimensions, and other measures are nominal and may vary by approximately 2 %.

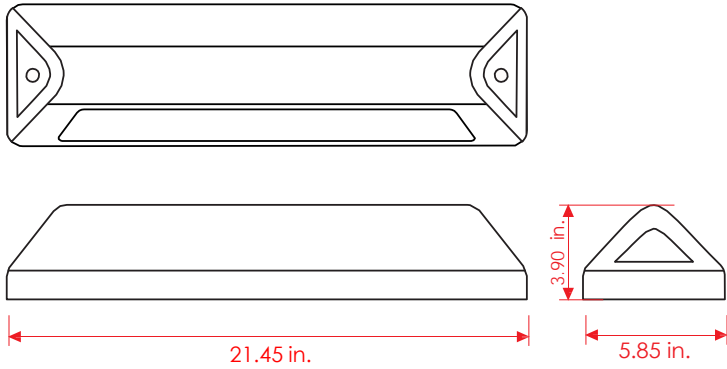

Measures

Material:	Polymer blend.
Dimensions:	
Length:	21.45 in.
Width:	5.85 in.
Height:	3.90 in.
Colors:	Black.
Approx. weight:	8.899 lb.

Installation

Mark the boreholes using the Parking stop as a template. Bore into the holes with a drill and a 1/2" drill bit at a depth of 5".

Fill with epoxy glue.

Place the Parking stop and carefully hammer the nails on each hole making sure not to mistreat it.

Suggested use



**Installation on
asphalt**
7/16" x 6 in. Steel nail