

A leader doesn't follow steps  
... he marks the way

# ABS SUPER ROAD STUD

## TP-25

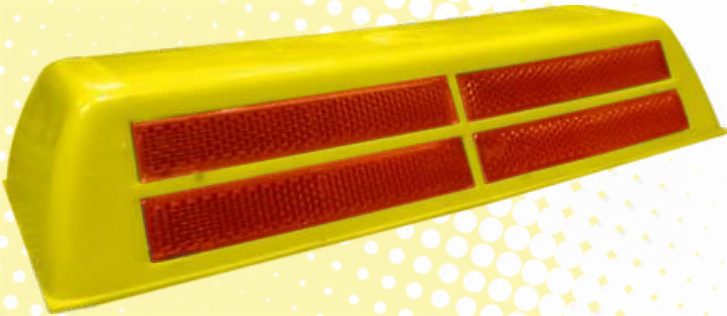

### Features

- A trapezoidal-shaped safety device.
- An accessory designed in ABS plastic for work protection.
- The resistance to UV rays and weather guarantees its long working life and avoids breaks.
- Easy to clean. It has resistance to liquids and solvents.
- It frequently serves as a lane separator or speed bump on medium and high-speed highways.
- It has four amber or red reflective stripes on its front of 2.4 in<sup>2</sup> to increase its visibility at night.
- Two plastic bolts (optional).

### Technical specifications

- \* Made of: Medium-density polyethylene.
- \* Approx. weight: 4.68 lb.  
Sup: 7.6 in. Lower diameter: 16.18 in.
- \* Dimensions: Height: 3 ft 9 in.
- \* Optional reflective: Engineer Grade (other grades of reflective upon request).

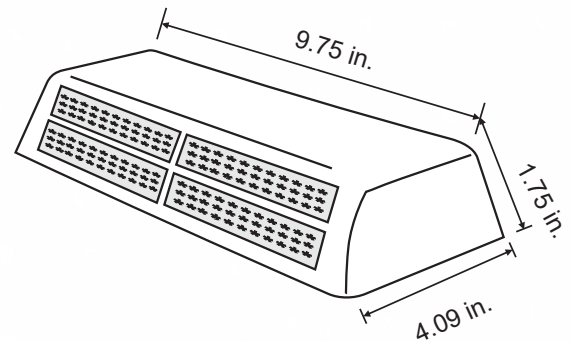

Volumes, dimensions, and other measures are nominal and may vary by approximately 2%.