

# Multimessage Trailer

CODE: RE-MUL

Leader don't follow steps  
... marks the way

## WHAT IS THE MULTIMESSAGE TRAILER?

- It's a modular traffic signaling electronic system mounted in wheels and composed by:
  - A) Trailer with winch.
  - B) Lighten board and controller box.
  - C) Shock absorber with lights.
  - D) Solar system and circuitry needed for its operation.
- **IMPACT ABSORBER:**
  - Designed for handle impacts against the signalisation and to protect other structures, is all weathering resistant (including snow,rain and UV rays). Is black color with reflective diagonal stripes in amber for a better nightly visibility. Has 6 caution lights that indicating turn right, left, stop and reverse with hided wiring. Its shock absorption capacity, like a big cushion, is determined by different Vitemflex® layers, a special material that integrates very tiny bubbles with air. The device is completely harmless to vehicles, people or wild fauna.



- **TRAILER:** Manufactured in hollow square tube (HST) 2.5", angle 1/2"x1/8" and galvanized dye sheet cal. 16 with primary coating and yellow enamel.Has a spring suspension system, support axis with a 1,800 LBS capacity and a winch to support 1,800 LBS too, includes a mechanical jack for a better positioning elsewhere.

- **AMBER MONOCROMATIC LIGHTEN BOARD**

- The luminic sign measure is 44,09 in. X 75,59 in. and it can display up to 25 programmable messages with a software that runs in the most common operative system (Windows). Also has a protection cabinet against weathering structured out in HST 4"X2" with a cover on metal dye sheet cal. 18 with primary coat and black enamel.

- **SOLAR POWER SYSTEM**

- The luminic board is feeded by solar energy combine with a battery pack 60W-12V-40AH.



Images are merely illustrative models.



# Multimessage Trailer

CODE: RE-MUL

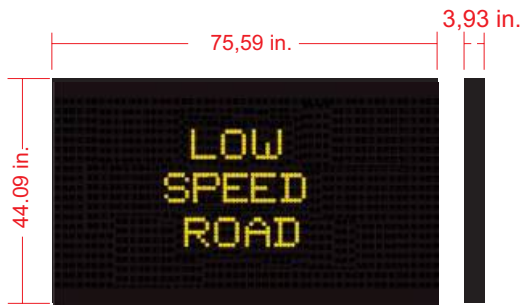

AMBER MONOCROMATIC LIGHTEN BOARD

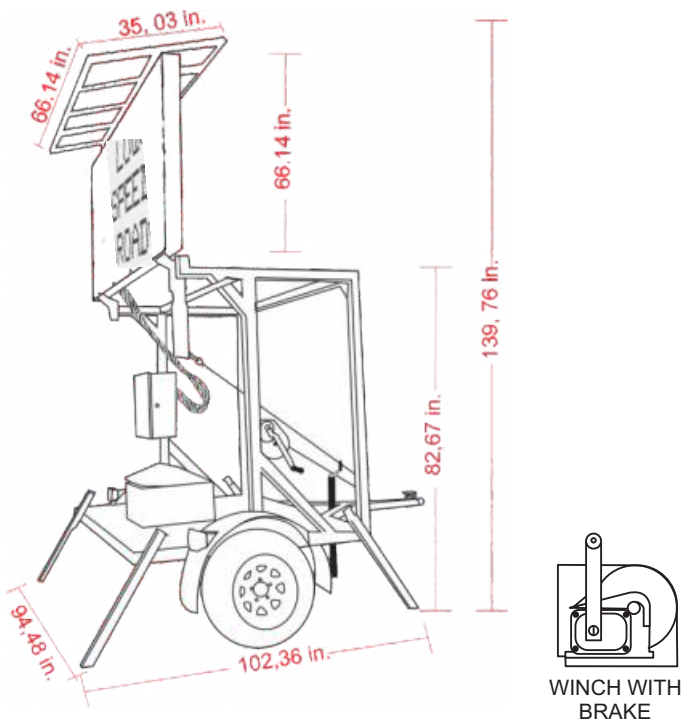

WINCH WITH BRAKE

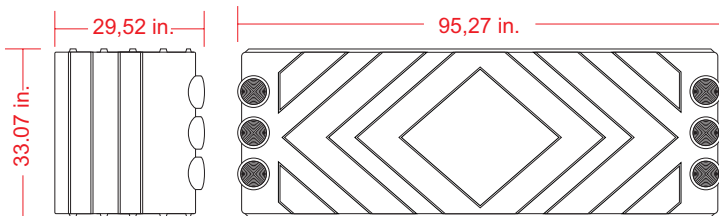

Measures are nominal and can vary, between +- 2%

## Technical Data

### Trailer

**Manufactured out in:** Hollow Square Tube (HST) 2.5" galvanized HST 1.5"; Angle 1 1/4" x 1/8" galvanized dye sheet 4" x 8" cal.16.

**Color:** Traffic Yellow

**Measure:** Trailer 94,48 x 102.36 in.

**Suspension:** Springs system

**Platform:** Axis support 1,500 lbs.

**Winch:** 1,800 lbs.

### Impact absorber

**Manufactured out in:** Vitemflex ®.

**Measure:** Length: 242 cm Alto: 84.0 cm Ancho: 75.0 cm

### Lighten Board

**Made out in:** HST 4" x 2". black dye sheet cal.18.

**Measure:** Length: 75.59 in. Height: 44,09 in. Width: 3,93 in.

**Total weight:** 198,41lbs.

**Powered:** 12 Volts.