

# 51 Speed Hump

Code: CRR-51

True leaders do not follow  
...they lead the way

## WHAT IS A CCR-51 SPEED HUMP?

Devices installed on the asphalt surface, designed to regulate speed in specific areas.

They are especially recommended in school zones, pedestrian crossings, hospital areas, and anywhere speed reduction is necessary.



- Ultrafix Hex Head Screw 21 V  
Ø 3/8" x 5.9"
- Extralarge anchor plug  
Ø 0.75" x 5.5"

## Features

- This speed hump is designed in modules, allowing adjustment to the required length.
- Its dynamic shape makes it urban-friendly.
- Male-female assembly with end caps.
- Made from polyethylene, a material that does not damage vehicles.
- **Each piece is produced in solid, highly durable colors (black, green, and yellow) with UV protection to prevent fading.**
- No sharp vertices or edges that could harm users.
- Adaptable to any type of flat pavement.
- Can be used to confine bike lanes.
- Optional: can include illumination.
- **Easy installation: each piece has 2 boreholes for fastening to the ground using anchor plugs or steel bolts.**

### LIGHTING FEATURES

- Smart solar-powered system integrated.
- High-efficiency solar panel and electronic system.
- Amber and blue LEDs with a 30° operating angle.
- Flashing frequency: 3Hz



# 51 Speed Hump

Code: CRR-51

Dimensions and other measurements are nominal and may vary by  $\pm 2\%$

Dimensions are in **inches**

Example:  
**CRR3 overall length:** 51 in  
**CRR4 overall length:** 71 in

Dimensions		Approximate weight
<b>Dimensions:</b>		
<b>Female head length:</b>	15.7 in	4.09 lb
<b>Overall length of central module:</b>	22.2 in	5.4 lb
<b>Functional length of central module:</b>	19.7 in	
<b>Male head length:</b>	18.3 in	4.6 lb
<b>Width:</b>	5.8 in	
<b>Overall length:</b>	1.97 in	
<b>LED color:</b>		Amber, blue or red

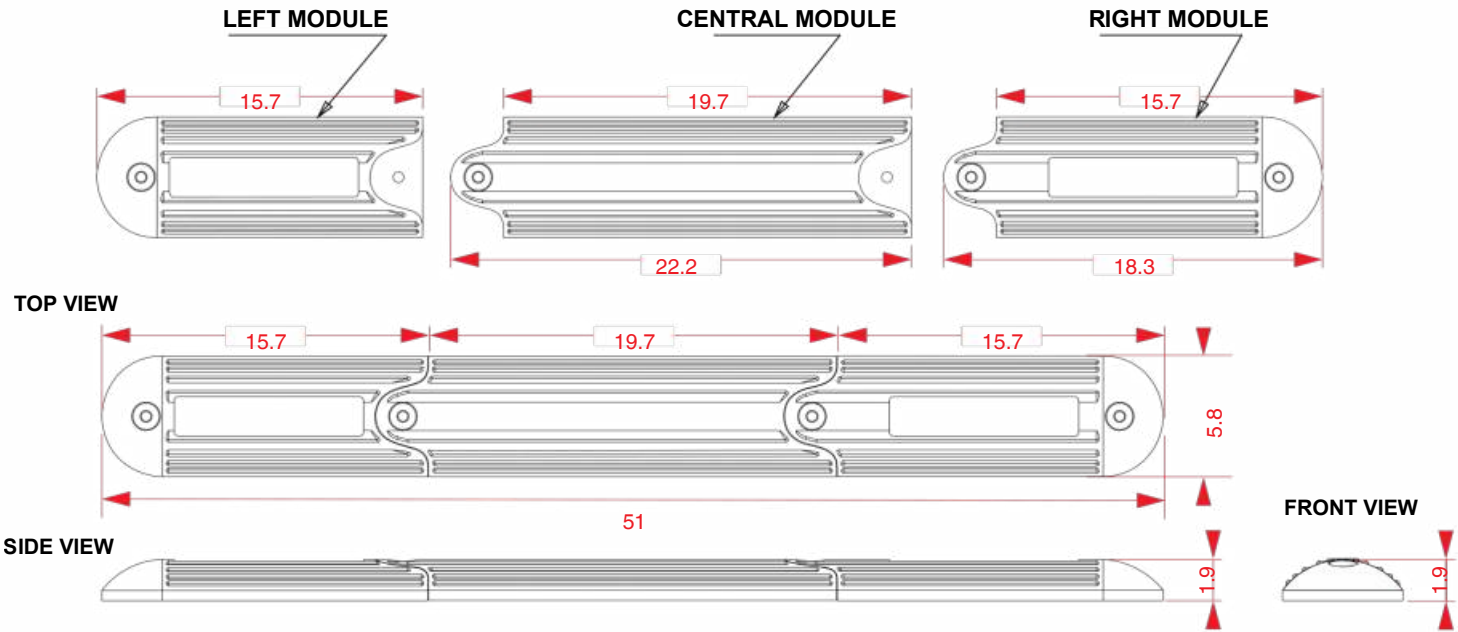

anchoring procedure



**Anchoring procedure on asphalt:**

1. Outline the position of the holes using its base as a template.
2. Drill the boreholes with a 3/4" concrete drill bit to a depth of 7".
3. Fill the hole with epoxy resin.
4. Insert the anchor plugs, then position the product and insert the 3/8" x 15 cm screws with flat washers.
5. Tighten the screws using a 9/16" socket.

**Anchoring procedure on concrete:**

1. Outline the position of the boreholes using the base as a template.
2. Drill the holes with a 3/4" concrete drill bit to a depth of 7".
3. Fill the borehole with epoxy resin.
4. Place the bollard in position and insert the anchors (steel nails).
5. Hammer the anchors (steel nails) carefully, taking care not to damage the product.

An illustration showing the hump being anchored into a surface. It depicts the hump being placed over a hole, with screws and anchors being inserted into the pre-drilled holes to secure it.