

SPEED DETERRENT RAMP WITH INTEGRATED LIGHTNING

Code: TRP-75



**True leaders do not follow
...they lead the way**

WHAT IS A SPEED DETERRENT RAMP?

Modular speed hump – This feature allows you to adjust the length to suit your specific pedestrian crossing needs.

Its primary function is to reduce vehicle speed. Additionally, it is perfect for creating crosswalks.

Perfectly suited for locations near schools, crosswalkings, hospitals, or any setting that demands lower vehicle speed.

Features

- Its trapezoidal design enhances safety for both drivers and pedestrians.
- Because they are interconnectable, they can be configured to cover any required area.
- Once the desired length is assembled, the center is filled with concrete, creating a pedestrian crossing.
- It features 4 reflective areas that are highly visible from a distance.
- Made of polyethylene, a vehicle-friendly material that won't cause damage upon contact.
- Withstands frontal and lateral vehicle impacts, making it virtually unbreakable.
- The perfect alternative to traditional concrete speed bumps.
- Non-skid surface.
- Available in high-visibility colors: white, black, and yellow.
- Maintenance-free.
- Its 7 strategically placed boreholes ensure secure installation.
- Optional integrated lighting enhances nighttime visibility.

LIGHTING FEATURES

- It features ultra-bright white LED lamps inside.
- Direct-line connection with automatic ON-OFF protection sensitive to ambient light.



SPEED DETERRENT RAMP WITH INTEGRATED LIGHTNING

Code: TRP-75

Dimensions and other measurements are nominal and may vary by $\pm 2\%$

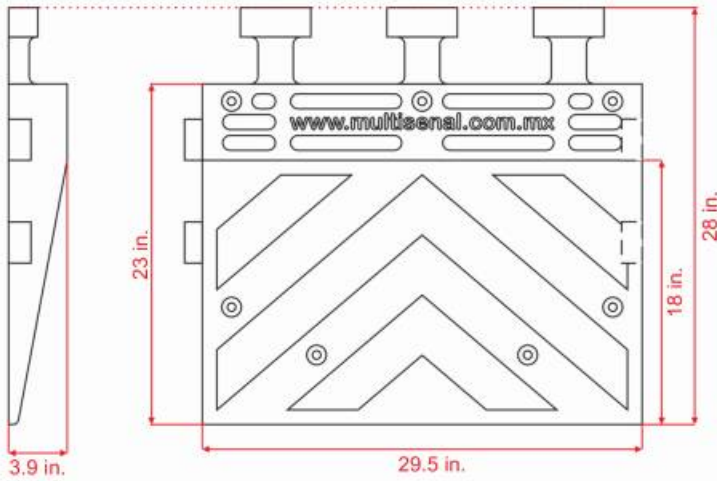

Measures

Overall functional dimensions:

Length: 29.5 in., Width: 23 in., Height: 3.9 in.

Reflective:

A high-intensity prismatic type

Reflective color:

Amber or white

Approximate weight:

48 lb

Using a drill and a 1/2 in. concrete bit, mark the boreholes using the ramp as a template. Proceed to drill the marked spots to a depth of 3 in. Then, position the ramp, insert the anchors, and nail them in with a 6-pound sledgehammer until fully seated. Be careful not to damage the product during installation. Your deterrent ramp is now properly installed.

