

Ecoflex® 125 Solar Delineator Post

Code: ECOFLEX-125S

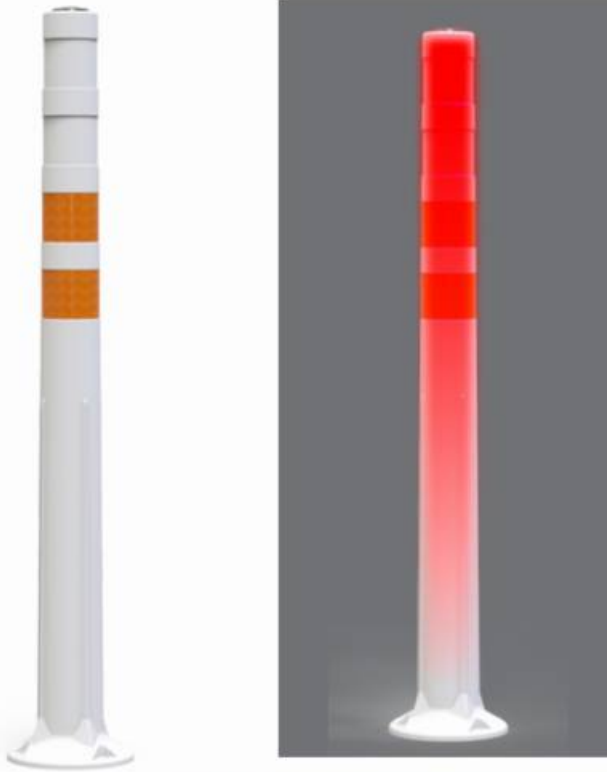

We are on the next level!

A POST TO YOUR LEVEL

Devices are designed to demarcate, delineate, and guide transit in different types of roads and spaces for a parking lot.

These are fundamental elements for road safety, helping to organize vehicle and pedestrian flow efficiently. In addition, contribute to the channelization of bikeways and signage in forks, providing a clear orientation at key points of road infrastructure.

These devices are also useful in the creation of refuge islands in pedestrian crossings, separating pedestrians safely from vehicles and avoiding accidents.

In areas for lane bifurcation or transition zones, posts help to guide motorists and cyclists to correct routes, improving circulation and reducing the risk of non-desired deviations.

Equipped with high-intensity LED lighting, posts guarantee optimal visibility during day and night, crucial for safety in high-speed tracks or in low-light conditions.

These are designed to withstand impacts and extreme temperature changes, without losing integrity, are easy to install, visible from different distances and angles, guaranteeing their presence is always seen in roads, parking lots, or corresponding traffic zones.

These have solar cell systems to recharge the battery of LEDs, guaranteeing they are lit without manual intervention.

Features

- Ecoflex125 delineator post is manufactured in poliflexy® with the aim that this is rigid enough to stand, if impacted can regenerate and return to initial position.
- Body manufactured in a single piece, base with gussets made of the same material, increasing the resistance when ran over; base has 3 boreholes for an easy and safe installation.
- Line color: translucent white.
- 4 reflective tapes “A or B” type, as required on project, that guarantee a greater visibility in dark environments.
- To fasten them, are recommended 3 screws with 3 extra-large anchors, providing them greater safety.
- In case of require a put and remove one, it has the option to include heavyweight base to avoid tilts caused by wind.
- Base manufactured in black polyethylene; with included grip to move easily.

SOLAR POWER SUPPLY SYSTEM

- Solar cell for automatic charge.
- 2 lithium polymer batteries that provide a backup power source.
- 1 ultrabright LED in white, blue, or red color, with flashing light for greater visibility and safety.
- JVM circuit that controls the ON and OFF of the flashing light.
- Easy synchronization with other signage devices, if necessary.



Reflective Sheeting



Anchoring



Solar cell



Base with handle

Ecoflex® 125 Solar Delineator Post

Code: ECOFLEX-125S

Dimensions and other measures are nominal and may vary by + - 2%.

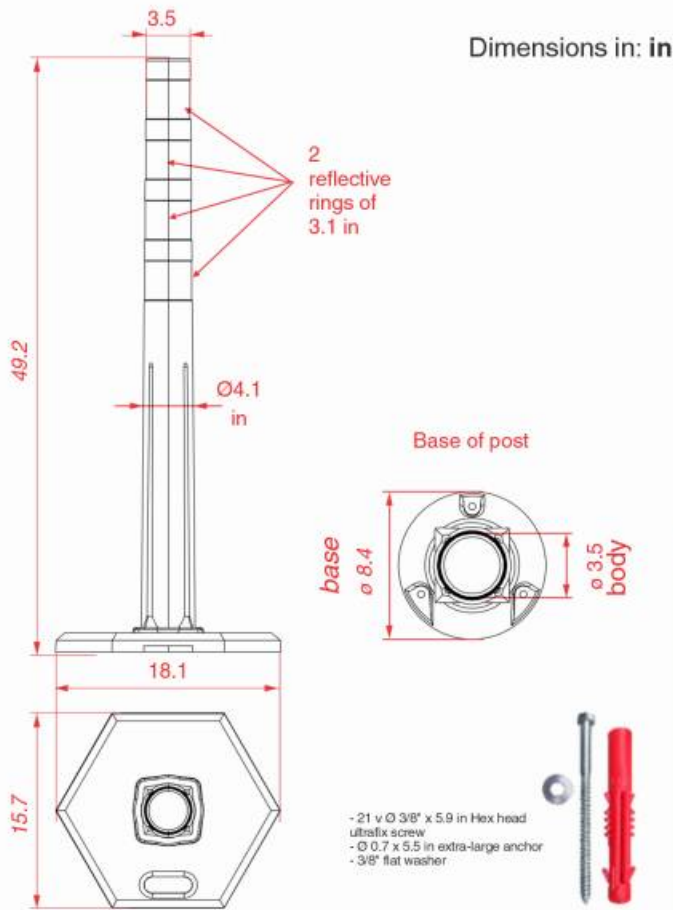

Measures

Total	Height: 49.2 in top ø. 3.5 in. base ø 8.4 in.
Base	15.7 x 18.1 in x 1.5 in of height
Reflective Sheeting:	4 rings
Color of reflective sheeting:	White, amber or two colors.
Approx. weight of post:	3.6 lbs.

Anchoring system

1. Mark the boreholes where the bollards will be placed (use device as a template)
 2. Drill the boreholes with a 3/4" drill bit for concrete to a 6" (15.24 cm) depth.
 3. Insert the extralarge anchors in every borehole and mount the bollard.
 4. Place the 3/8" x 5.9 in flat washer and anchors, then, tighten with a 9/16" socket wrench.
- Done!

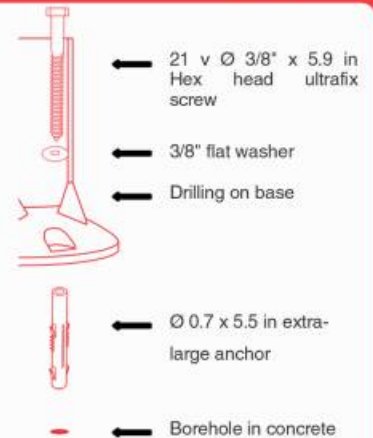

Note: For a better installation, add epoxy resin on holes.



more durability
more safety
more resistance
less cost