

# 85 Delineator Post

Code: IT-85

Images are for illustrative purposes only



True leaders do not follow,  
...they lead the way

## WHAT IS AN 85 DELINEATOR POST?

- Polyflexy® flexible posts, some equipped with a weighted base for enhanced stability.
- They provide effective and adaptable area delineation.
- Perfect for roadworks, detours, gores, parking areas, exposed manhole, and more.

## Features

- Flexible and efficient zone delineator post.
- Impact-resistant: withstands repeated vehicle contact and recovers its shape.
- Easy-to-hold end cap for simple handling and moving to any location; also suitable for securing safety tape, chains, or a lamp.
- Perfect for temporary road marking, providing quick and flexible setup.
- Manufactured with Polyflexy® body and solid PVC base.
- Durable under extreme weather and temperature variations.
- UV-resistant.
- Features 2 reflective rings for enhanced night visibility.
- Bright yellow for maximum visibility.



# 85 Delineator Post

Code: IT-85

Dimensions and other measurements are nominal and may vary by  $\pm 2\%$

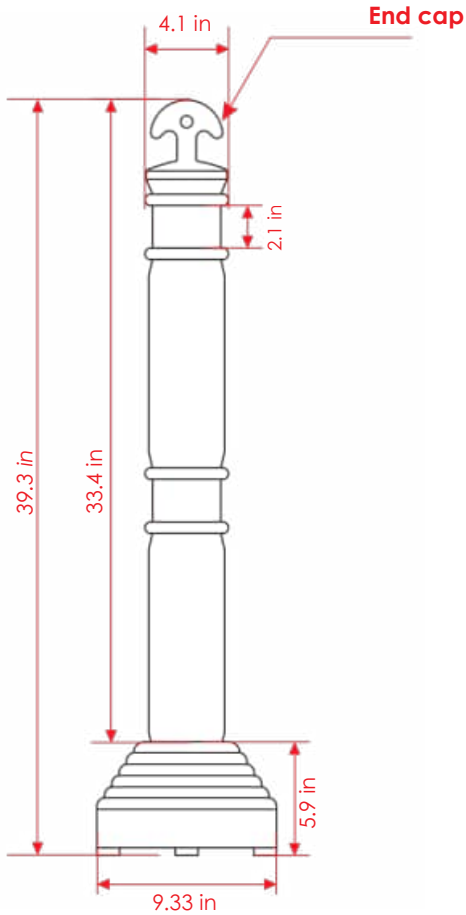

## Dimensions

### Overall dimensions:

Height: 39.3 in  
Diameter (base): 9.3 in

### Reflective strip:

Height: 2.1 in  
Width: 3.7 in

### Weight (approx.):

14.1 lb

### Reflective strip color options:

Amber or red

### Delineator post color options:

Orange or yellow

