

ICV-81 CHANNELING DELINEATOR POST

H
O
R
I
Z
O
N
T
A
L

T
R
A
F
F
I
C

C
O
N
T
R
O
L

D
E
V
I
C
E



Features

- Specially designed for contraflow lanes and for channeling heavy and light traffic.
- Features a 31.5 in base and a 25.5/19.7 in Vitemflex® post.
- Easy to handle, store, and transport.
- Resistant to UV rays, moisture, oil, and extreme temperature variations.
- Maintenance-free.
- Contributes to a safer environment.
- Highly durable.
- Suitable for all types of surfaces.

FOLDABLE POST

- Designed to return to its original shape after being flattened.
- Equipped with 2 or 3 white reflective rings that enhance nighttime visibility.
- Easy to install using 2 steel anchors (not included).

Technical specifications:

Base

- *Material: High-density polyethylene
- *Dimensions: Length: 32 in, Width: 6.3 in
Height: 3.3 in
- *Approximate weight: 8.49 lb
- *Color: Yellow

Milestone

- *Material: Vitemflex® 65 Milestone:
- *Dimensions: Ø 3.5 x 25.5 in high

Milestone

- *Material: Vitemflex® 50 Milestone
- *Dimensions: Ø 3.93 x 19.7 high

- *Color: Yellow, green or orange

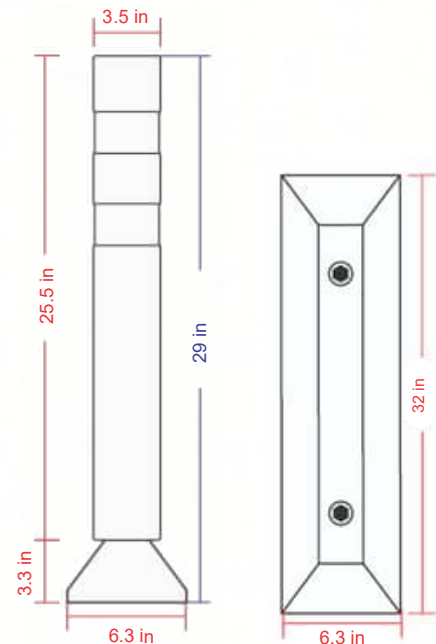

Dimensions and other measurements are nominal and may vary by ±2%