

# REBOUNDABLE DELINEATOR POST

Codes: IT-AB-03, IT-AB-02, IT-AB-01

True leaders do not follow  
...they lead the way

## WHAT IS THE FOLDING DELINEATOR POST?

- Folding and space separator, this delineator post is detachable and practical, designed with modular components.
- Featuring a floor-mounted adaptable base.
- Reflective bands that ensure long-distance visibility.
- 360° mobility with tilt up to 45 degrees.
- Perfect for managing vehicle access in parking lots, school zones, gores, and similar areas.



## Features

- Highly useful in construction sites, counterflow lanes, detours, gores, parking lots, etc.
- With UV protection for extended durability.
- Resistant to weather conditions and extreme temperature changes.
- Impact-resistant, returning to its original position after collisions.
- High-visibility colors: yellow, blue, green, orange, black, or white.
- High-quality reflective bands ensuring visibility both day and night.
- Detachable threaded components.
- Available with 1, 2, or 3 modules to adjust size as needed.
- Easy to transport.
- Circular base with excellent stability, featuring a central spring that ensures the post returns to its original upright position.
- Anchored to the floor with four 3/8" anchor plugs, four 5/16" x 2" hex-head screws with flat and lock washers (not included).



# REBOUNDABLE DELINEATOR POST

Codes: IT-AB-03, IT-AB-02, IT-AB-01

Dimensions and other measurements are nominal and may vary by  $\pm 2\%$

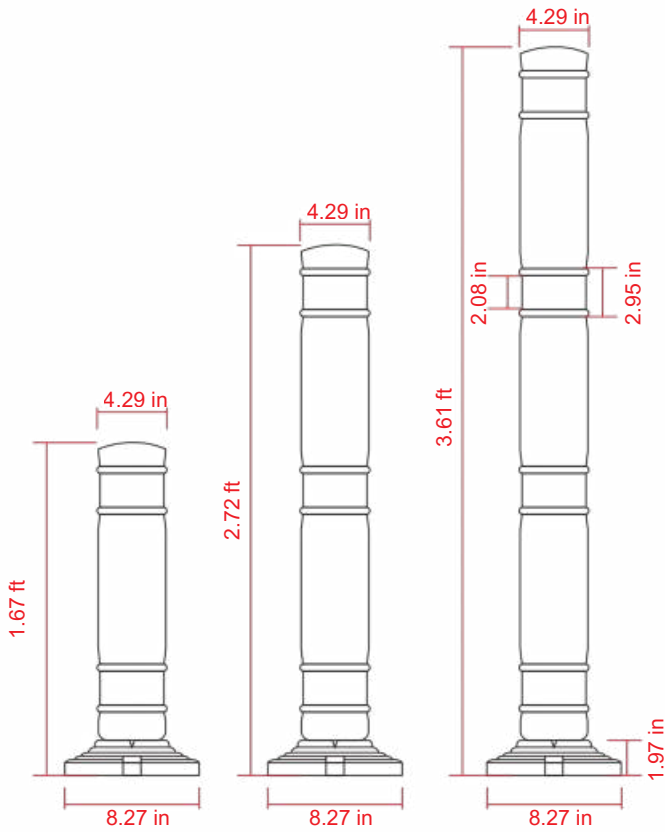

## Dimensions

**Material:** High-molecular-weight polyethylene  
**Module colors:** Available in white, orange, yellow, and black

### Overall dimensions and weight:

1-module delineator post:	1.67 ft high	2.1 lb
2-modules delineator post:	2.72 ft high	2.63 lb
3-modules delineator post:	3.61 ft high	3.25 lb

**Base or support material:** Medium-density polyethylene  
**Color:** Black  
**Reflective (optional on rings):** Engineer grade (EG), High Intensity, or Prismatic  
 - **Gloss (85° reflectometer):** Over 40°.  
 - **Tensile test (300 mm/min):** Approximate strength: 32.0 psi.  
 - **Heat resistance (159.8  $\pm$  37.4°F for 24 hrs):** No effect.  
 - **Cold resistance (-70  $\pm$  37.4°F for 7 hrs):** No effect.

## Anchoring system

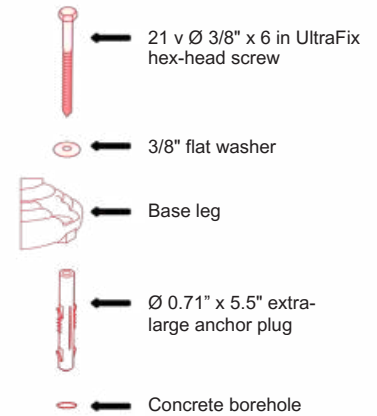

Trace the anchor borehole positions on the floor using the base as a template. Drill the designated area with a  $\frac{3}{4}$ " concrete bit to a depth of 7 in. Insert the anchor plugs into the boreholes, position the delineator post, and insert the  $\frac{3}{8}$ " x 6" screws with flat washers. Tighten all four screws using a  $\frac{9}{16}$ " socket. Installation is complete.

