

MINI TOP 445 LANE SEPARATOR

Code: MINITOP-445



WHAT'S A MINITOP?

Perfect to delimit and channel lanes or bike lanes, as well as working like a traffic guide.

It has the option of adding a Poliflexy® 66 Bollard.

The Minitop 445 can work as a speed hump or as a lane separator.

It reduces the speed to 1-4 mph approximately.

Features

- It can be installed on any flat surface.
- Perfect to strengthen stop signs.
- Designed for immediate installation.
- It's resistant to any frontal or side impacts which makes it practically unbreakable.
- It doesn't fall apart, cracks, or rot.
- UV protection.
- Humidity, oil, and weather resistant.
- Male-female assembly.
- Easy to install with five Ultrafix hex-head screws of 3/8" x 5.85 in. and 5 Extralarge polyethylene anchors of 0.70 in. x 5.46 in. (not included).
- Maintenance free.

AS A TRAFFIC LANE CHANNELIZER

- It can also work as a traffic lane channelizer by combining the lane separator with a bollard.
- First, the **MINITOP 445** Lane Separator is made of HDPE.
- Secondly, the material of the 66 Bollard is Poliflexy®, a material that doesn't damage vehicles in case of impact and is the perfect combination between softness and resistance.
- This modern, attractive, and functional product provides safety to the user and offers a pleasant view of the road.
- Perfect for bikeways and contraflow lanes.

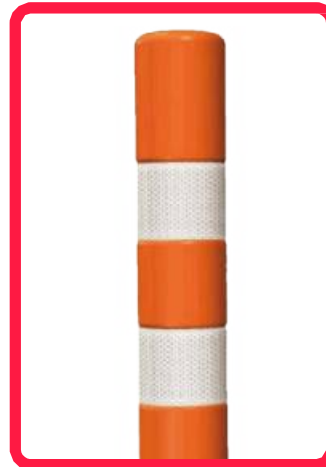

MINI TOP 445 LANE SEPARATOR

Code: MINITOP-445

Volumes, dimensions, and other measures are nominal and may vary by approximately 2%.

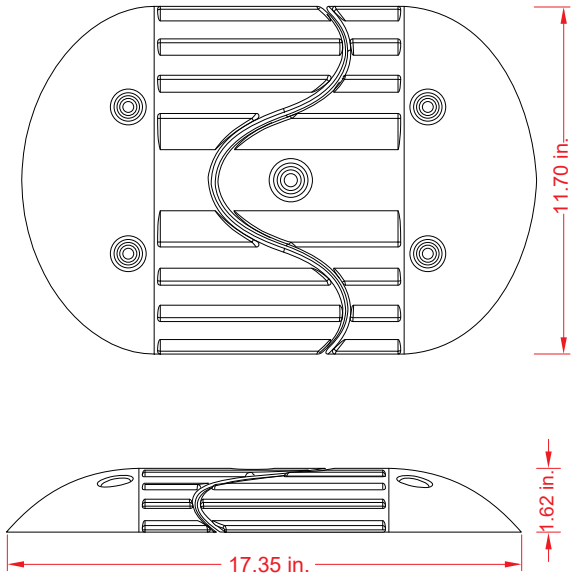

Measures

LANE SEPARATOR

Material: HDPE.
Weight: 5.69 lb.
Lane separator measures: Length: 17.35 in.
Height: 1.75 in.
Width: 11.70 in.
Colors: Yellow and black.

Traffic lane channelizer measures: Length: 17.35 in.
Height: 26.91 in.
Width: 11.70 in.
Colors: Orange or yellow bollard.



Installation
with epoxy
glue

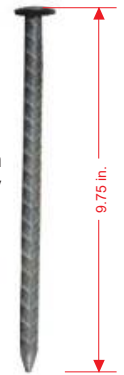

Installation in asphalt
Steel nail (1/2" × 9.75 in.)