

Central Reflective Channeler

Code: CRR-183

Measures are nominal and can vary, between +- 2%

Leader don't follow steps
... marks the way



Registered in the Mexican Institute of Intellectual Property (IMPI) Exp. MX-f-2008/001244.

TECHNICAL DATA:

BUMP

Manufactured out in Low density polyethylene.
Color: Traffic yellow.
Measure: Length: 72 in., Height: 2 in.,
Width: 11.02 in.

SPHERE

- * **Optics:** Tempered sand-blasted silicon glass.
- * **Dimensions:** Diameter 3.93 in. Height: 0.19 in.
- * **Color:** Natural translucent.
- * **Treatment:** Silvered (high reflectiveness).

FEATURES

- Help to reduce vehicles speed down to 5 m/ph.
- Shock and heavy impact resistant, completely solid.
- Environmental friendly, its component does not harm people, fauna or plants.
- U.V. rays protection integrated.
- Easy to transport, due to its weight and its form.
- Extended durability.
- Lifesaver and risk reducer on roadways.
- Six reflectives spheres for an utmost visibility.
- Perfect anchorage with 3 augers along its body.
- No need special treatment or any finish, easy to clean from any leftover.
- Attrition resistant, its shows not decay, maintain in perfect stable excellent condition thru a long life service under conditions of humidity, weathering, salty or acid agents.
- Its resistance surpass any other material like wood, metal and else.
- Does not rot or crack, inoxidable, its 100% permeable, and resistant to alcohols, solvents, strong temperature changes, is flexible and 100% recyclable.

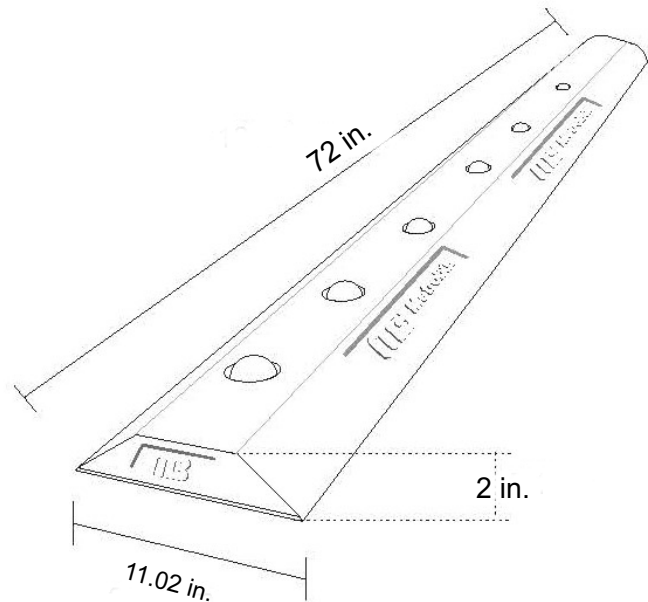

TECHNICAL DATA:

REFLECTIVE GLASS DETAIL

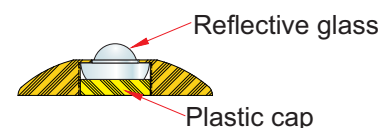

Images are merely illustrative models.