

51C-2 LANE SEPARATOR

Code: C51C-2

A leader doesn't follow steps, **he marks the way.**



WHAT'S A LANE SEPARATOR?

This device is perfect for safely channeling or directing vehicular traffic, cyclists, or pedestrians.

It has a modular base and a 100% flexible bollard with two reflective stripes that grant it better visibility at night.

Optimizes traffic flow and promotes road safety.

This lane separator is perfect for contraflow or bike lanes, to separate special lanes, delimit danger zones, etc.

Features

- Every middle section has a length of 15.6 in. which means that you can create different lengths according to your needs.
- Impact and rolling resistance.
- The lightweight body makes it easy to transport.
- The material of the lane separator is polyethylene in black, yellow, or green and the bollard is made of Poliflexy® in orange, yellow or green.
- The rounded edges provide great security in case of collision.
- It doesn't have metallic parts and doesn't break, fragment, or damage vehicles or people.
 - Male-female assembly.
- The bollard bears hits and impacts returning to its original shape every time.
- It includes two reflective stripes that make it visible at greater distances by increasing its visibility with the reflection of car lights.
- UV protection.
- It has two boreholes for fastening.
- It can be installed with steel nails or Extralarge anchors.
- Maintenance free.

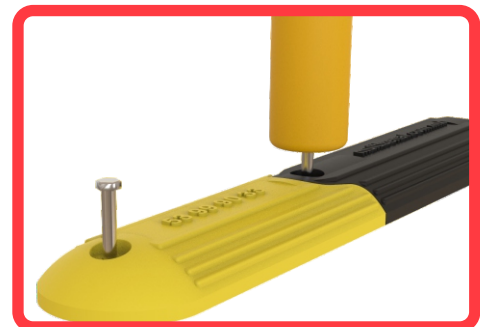

51C-2 LANE SEPARATOR

Code: C51C-2

Volumes, dimensions, and other measures are nominal and may vary by approximately 2%.

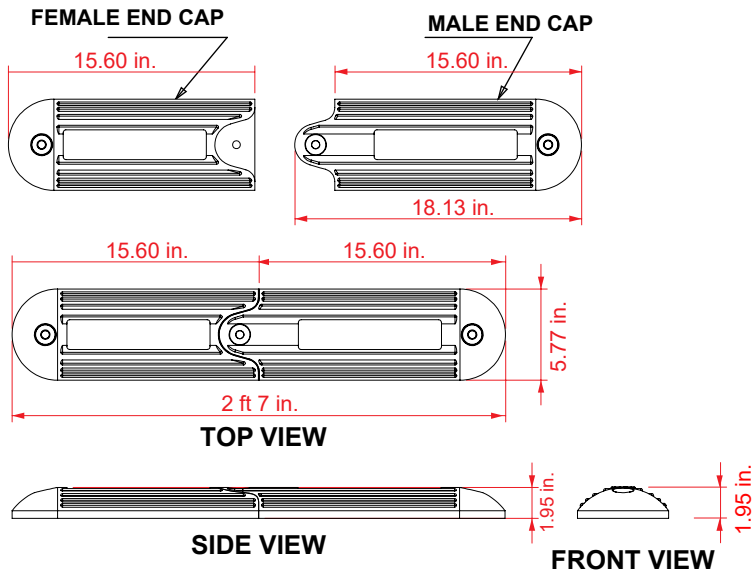

Measures

Material:	Polyethylene.	Weight:
Measures:		
Female End Cap:	15.60 in.	4.08 lb.
Male End Cap:	15.60 in.	4.62 lb.
Height:	1.95 in.	
Height with bollard:	27.10 in.	
Colors:	Yellow, green, and black.	

Installation in asphalt:

Steel nail \varnothing 1/2" \times 9.75 in.



Extralarge anchor:

- Ultrafix hex-head screw 21v \varnothing 3/8" \times 5.85 in.
- Extralarge anchor \varnothing 0.70 in. \times 5.46 in.



Installation in concrete:

- 1.- Use the lane separator as a template and mark the boreholes.
- 2.- Bore into the holes with a drill and a 3/4" concrete drill bit to a depth of 7".
- 3.- Fill the borehole with epoxy glue.
- 4.- Place the anchors and the lane separator.
Insert the 3/8" \times 5.85 in. screws with the flat washers.
- 5.- Tighten the screws with a 9/16 socket wrench.

Installation in asphalt:

- 1.- Use the base as a template and mark the boreholes.
- 2.- Bore into the holes with a drill and a 3/4" concrete drill bit to a depth of 7".
- 3.- Fill the borehole with epoxy glue.
- 4.- Place the lane separator and insert the nails.
- 5.- Carefully pound the nails using a hammer.

