



True leaders do not follow
....they lead the way

WHAT IS A SOLAR-POWERED ROAD MARKER LIGHT?

Solar -powered pavement marking device for highways and public roads that indicates traffic direction, highlights hazardous or restricted areas, and guides drivers to remain within the correct lane through roadwork zones, temporary detours, bike lanes, and related environments.

The unit consists of an aluminum marker with a glass sphere inside, providing high visibility over long distances, both day and night.

Features

- Up to three times lighter than steel while maintaining the same structural durability.
- Its size provides excellent visibility both day and night.
- Perfect for use as a speed reducer in pedestrian or school crossings, and as a lane or parking space divider.
- Its strong, corrosion-resistant body ensures long-lasting performance.
- Simple installation on any road surface, with optional two-bolt anchoring.
- Features a clear polycarbonate bead with advanced SMD LEDs that provide bright, all-angle visibility.
- The lighting system is simple to synchronize.

LIGHTING SYSTEM

- Solar panel cell.
- Lithium-polymer rechargeable batteries.
- Ultra-bright, high-intensity LEDs.
- Flashing light

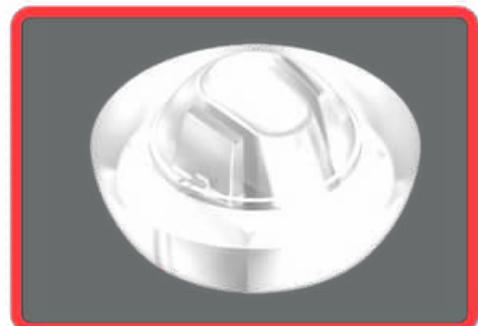

Aluminum Solar-Powered LED Road Stud

Code: BA-180-SOL

Dimensions and other measurements are nominal and may vary by $\pm 2\%$

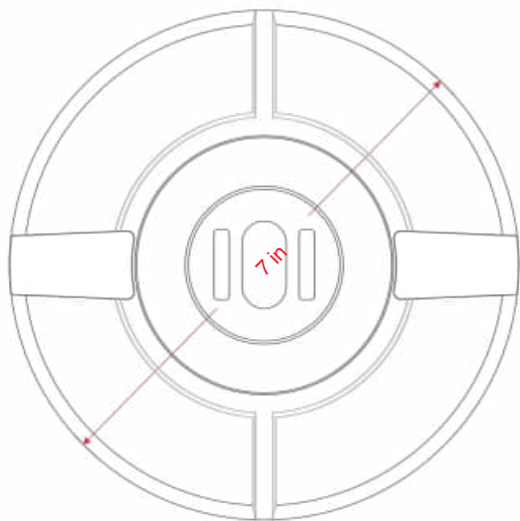
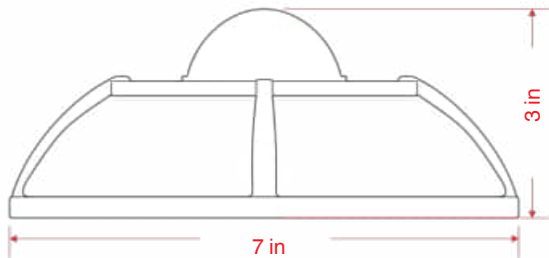

Dimensions

* Material:	Aluminum 380.2
* Dimensions:	Diameter: 7 in, Height: 3 in
* Material color:	Natural
* Weight:	3 lb
* Friction resistance:	Over 50 times that of plastic

	Bead
* Material:	Polycarbonate
* Material color:	Natural

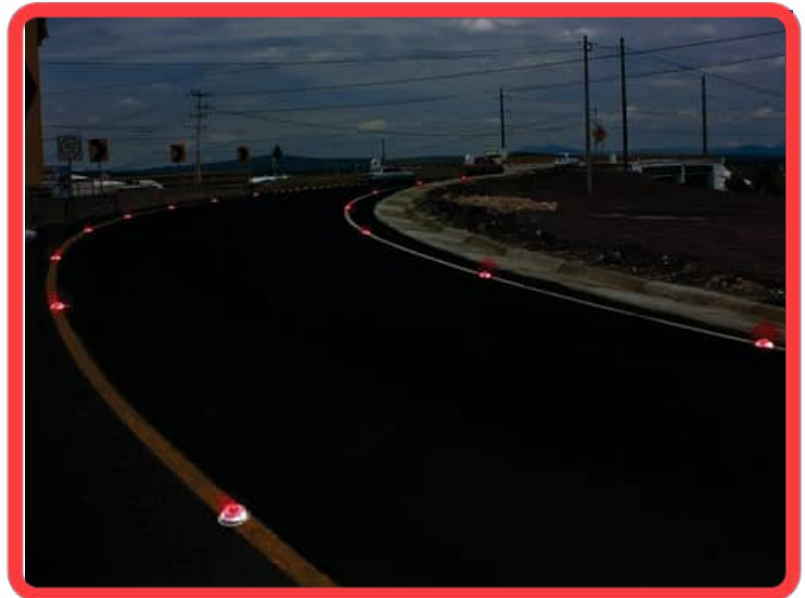

Anchorign system

Road studs are installed by hand, usually with epoxy for secure adhesion.

1. Ensure the surface is dry and clean. Mark the location of each road stud according to the desired layout.
2. Apply approximately 5.3 oz of epoxy to the back of the road stud, ensuring full coverage.
3. Place the road stud and apply pressure. It does not matter if some epoxy protrudes, as this helps achieve better adhesion to the surface.
4. If using a bolt, drill a $\frac{1}{2}$ " hole to 3" deep and remove any excess dust. Optionally, apply a small amount of epoxy in each hole for extra hold.
5. Let the epoxy cure for about 2 hours before traffic or handling.

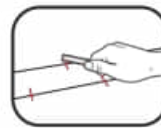

PREPARING THE EPOXY RESIN

- Mix equal amounts of formula "A" and "B".
- Stir thoroughly until a uniform mixture is achieved.
- Once the task is finished, discard any leftover epoxy resin, as it cannot be reused.

