

# I-68 Channel Pavement Marker

Code: I-68

A leader doesn't follow steps, **he marks the way.**

## WHAT'S A CHANNEL PAVEMENT MARKER?

This horizontal road traffic control device works mainly as a speed hump, parking stop, or zone delineator in roadways, highways, and city streets.

It has the perfect height since it doesn't damage tires thanks to its visually attractive and practical design.

It optimizes road traffic and promotes road safety.

It's mainly used for channeling traffic flow and bringing safety in possible dangerous zones like bridges, tunnels, slopes, or curves.

It also serves as a road channelizer.



## Features

- Perfect to delimit public transport lanes, bike lanes, speed bumps, bifurcations, etc.
- It's almost indestructible since it has high resistance to traffic collisions.
- Offers low friction to tires.
- Made specially to endure heavy traffic.
- Color: Yellow.
- Maintenance-free.
- The state-of-the-art design makes it a functional road element.
- The specialized reflectives work from any side.
- It doesn't have corners or sharp ends that could harm the user.
- Adaptable to any kind of pavement.
- Easy to install due to its four boreholes on each end.



# I-68 Channel Pavement Marker

Code: I-68

Volumes, dimensions, and other measures are nominal and may vary by approximately 2%.

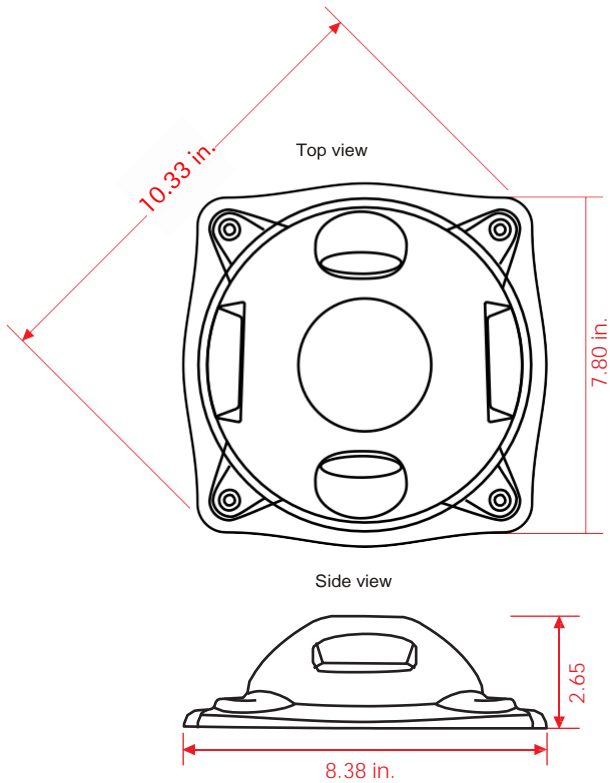

## Measures

<b>Material:</b>	Polyethylene.
<b>Measures:</b>	Length: 8.38 in. per side Height: 2.65 in.
<b>Weight:</b>	1.16 lb.
<b>Reflective surface per side:</b>	1.20 sq in.
<b>Effective contact surface:</b>	43.52 sq in.



## Installation.

The surface needs to be dry and clean. Mark the distribution of every channel pavement marker.

Two installation methods:

- **Asphalt:** Mark the four boreholes. Place the channel pavement marker on the place assigned. Then start pounding. You can apply epoxy glue on the base (optional). Make sure not to mistreat the channel pavement marker by carefully pounding the four  $\frac{1}{4} \times 3$ " nails.
- **Concrete:** Mark the boreholes on the concrete with a  $\frac{3}{16}$ " drill bit to a depth of 3". Insert the four  $\frac{1}{4} \times 3$ " nails and pound them.

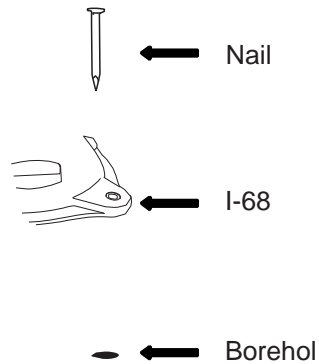

## EPOXY GLUE PREPARATION:

1. Mix equal amounts of the "a" and "b" formulas.
2. Stir until the formulas are well combined.
3. Since you can only use it once, get rid of the remaining epoxy glue once the job is finished.