

MULTI-VIEW ALUMINUM ROAD STUD

Code: BT-MUL-AL

A leader doesn't follow steps, **he marks the way.**



WHAT'S A ROAD STUD?

A retroreflective lane marker specially developed to effectively delineate the route in low visibility conditions.

Since it's useful, discreet, and practical, it doesn't distract the driver but draws their attention due to its reflective elements.

It's placed over the road surface and is perfect for channeling vehicle traffic, indicating circulation, making drivers reduce their speed, delimiting lanes, etc.

The spheres make it reflect which grant it better visibility at night.

Ideal in pedestrian zones, crossings, turnouts, and delimit parking lots.

Features

- Made of aluminum.
- It includes 5 metallic reflective acrylic spheres. You can add them on one or both sides of the road stud. It's perfect to confine and delimit lanes of one or two-way roads. You can place them on every type of road.
- It can bear the passage of vehicles from motorcycles to semi-trailer trucks. It doesn't break or lose its shape.
- Long-lasting due to its materials and manufacturing methods.
- It has the option of adding a bolt for optimal grip on the floor.
- Since the ABS bolt doesn't break and simply wears out, it doesn't damage tires in case of detachment.
- Easy to install and maintenance-free.
- High resistance to wear and tear, friction, weight, humidity, and rainwater.
- Usually, its installation needs epoxy glue. This glue is characterized by having high resistance to temperature, physical and chemical agents, and an excellent fastening and long-lasting service life.



MULTI-VIEW ALUMINUM ROAD STUD

Code: BT-MUL-AL

Volumes, dimensions, and other measures are nominal and may vary by approximately 2%.

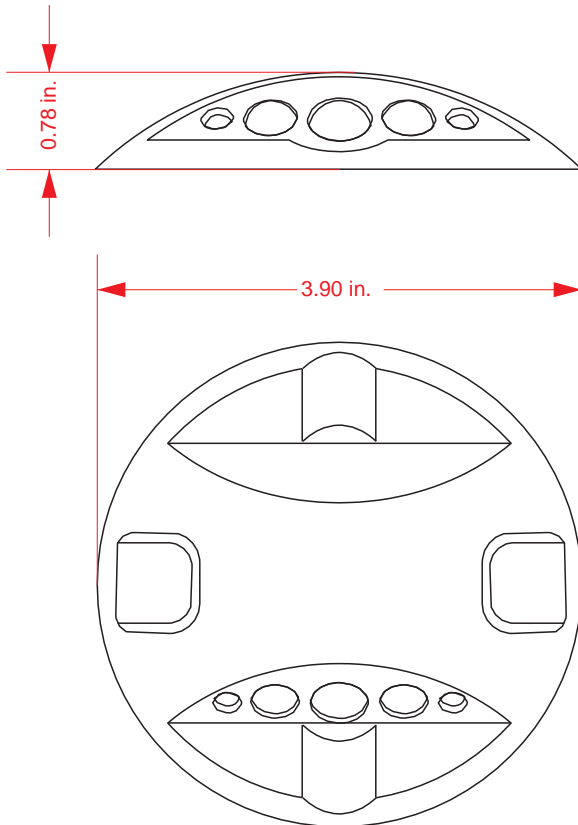

Measures

Total	Diameter: 3.90 in. Height: 0.78 in.
Reflective:	Acrylic spheres.
Reflective color:	Amber, white, red, and blue.
Weight:	3.5 oz.

Installation.

The installation is done by hand, usually with epoxy glue.

- 1.- The surface needs to be dry and clean.
Mark the road stud distribution (we recommend every 11 in. in staggered formation).
- 2.- Apply epoxy glue on the back of the road stud.
Make sure it's completely covered, especially the corners (approx. 3.5 oz).
- 3.- Put the road stud and press it.
It doesn't matter if the glue pours out.
- 4.- In case of having a bolt, bore into a hole with a 1/2" drill bit to a depth of 3".
Remove the excessive dust and return to step 2.
- 5.- Let it dry for approximately 2 h.

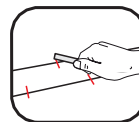

NOTE:

EPOXY GLUE PREPARATION

MIX EQUAL AMOUNTS OF THE "A" AND "B" FORMULAS.

STIR UNTIL THE FORMULAS ARE WELL COMBINED.

SINCE YOU CAN ONLY USE IT ONCE, GET RID OF THE REMAINING EPOXY GLUE ONCE THE JOB IS FINISHED..