

# STAINLESS-STEEL PAVEMENT MARKER

Code: BT-ACERO-INOX

A leader doesn't follow steps, **he marks the way.**



## WHAT'S A STAINLESS-STEEL PAVEMENT MARKER?

- A retroreflective lane marker specially developed to effectively delimit and channel the route in low visibility conditions on highways, streets, parking lots, bike lanes, pedestrian crossings, etc.
- Perfect to confine and delimit lanes on any type of road surface.
- Since it's useful, discreet, and practical, it doesn't distract the driver but draws their attention due to its reflective elements.
- It's placed over the road surface and is perfect for channeling vehicle traffic, indicating circulation, making drivers reduce their speed, delimiting lanes, etc.
- The spheres make it reflect which grant it better visibility at night.
- Ideal in pedestrian zones, crossings, turnouts, and delimit parking lots.

## Features

- The body doesn't deform and it's molded with stainless steel in one piece.
- The pavement marker doesn't damage vehicle tires since it doesn't have edges or corners.
- It includes 5 metallic acrylic reflective spheres.
- Long-lasting due to its materials and manufacturing methods.
- It has the option of adding a bolt for optimal grip on the floor.
- Since the ABS bolt doesn't break and simply wears out, it doesn't damage tires in case of detachment.
- Perfect as a speed hump in schools, pedestrian zones, and parking lots.
- Easy to install and maintenance-free.
- Usually, its installation needs epoxy glue. This glue is characterized by having high resistance to temperature, physical and chemical agents, and an excellent fastening and long-lasting service life.



# STAINLESS-STEEL PAVEMENT MARKER

Code: BT-ACERO-INOX

Volumes, dimensions, and other measures are nominal and may vary by approximately 2%.

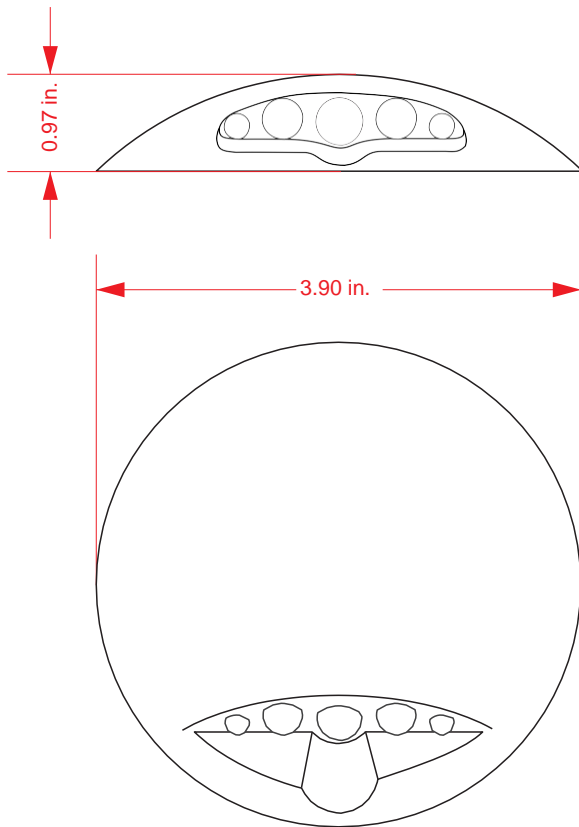

## Measures

|                    |   |
|--------------------|---|
| * Material:        | 430 Stainless Steel.  |
| * Sheet gauge:     | 18.   |
| * Finish:          | 2B.   |
| * Measures:        | Diameter: 3.90 in. Height: 0.97 in.<br>Height with a bolt: 2.34 in. |
| * Weight:          | 10.85 oz  |
| * Color:           | Natural.  |
| * Reflective area: | 2.02 × 0.46 in.   |

## Installation.

The installation is done by hand, usually with epoxy glue. (optional).

- 1.- The surface needs to be dry and clean.  
Mark the pavement marker distribution (we recommend every 10 in. in staggered formation).
- 2.- Bore into a hole with a ½" drill bit to a depth of 3".  
Remove the excessive dust.
- 3.- Apply epoxy glue on the back of the pavement marker.  
. Make sure it's completely covered, especially the corners (approx. 3.5 oz).
- 4.- Put the pavement marker and press it. It doesn't matter if the glue pours out.
- 5.- Let it dry for approximately 2 h.

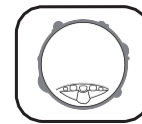
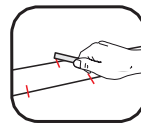

## NOTE:

### EPOXY GLUE PREPARATION

MIX EQUAL AMOUNTS OF THE "A" AND "B" FORMULAS.

STIR UNTIL THE FORMULAS ARE WELL COMBINED.

SINCE YOU CAN ONLY USE IT ONCE, GET RID OF THE REMAINING EPOXY GLUE ONCE THE JOB IS FINISHED.