

PLASTIC PAVEMENT MARKER

Code: BT-ABS

A leader doesn't follow steps, **he marks the way.**



WHAT'S A PLASTIC PAVEMENT MARKER?

- This pavement marker is specially developed to effectively delineate the road.
- Since it's useful, discreet, and practical, it doesn't distract the driver but draws their attention when they pass over the it due to its perfect height and vibrating effect.
- Ideal in pedestrian zones, crossings, turnouts, and delimit parking lots.
- Eye-catching colors depending on your project.

Features

- It's placed over the road surface and it's perfect for channeling vehicle traffic.
- It signals circulation, makes drivers reduce their speed, and delimits lanes, among other functions.
- It can bear the passage of any type of vehicles without breaking or losing its shape.
- Made of ABS in one piece with side gaps that facilitate its handling.
- Its materials and manufacturing methods make it a long-lasting product.
- Line colors: Yellow, white, blue, green, and red.
- Easy to install and maintenance-free.
- High resistance to wear and tear, friction, weight, humidity, and rainwater.
- UV protection.
- Usually, its installation needs epoxy glue.

This glue is characterized by having high resistance to temperature, physical and chemical agents, and an excellent fastening and long-lasting service life.



PLASTIC PAVEMENT MARKER

Code: BT-ABS

Volumes, dimensions, and other measures are nominal and may vary by approximately 2%.

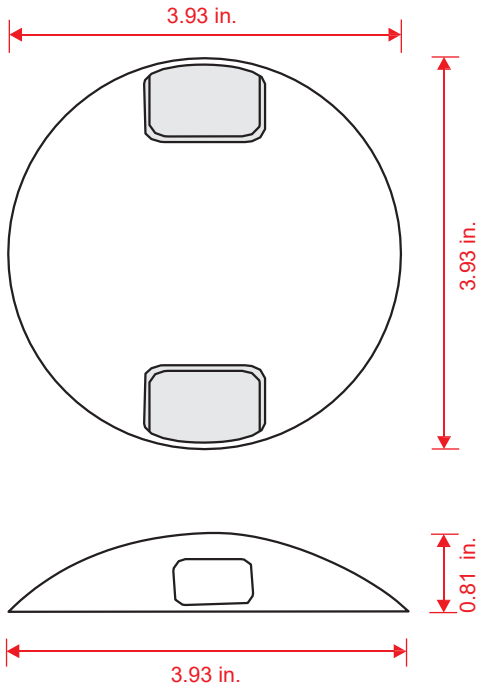

Measures

- *Measures:** Diameter: 3.93 in.
Height: 0.81 in.
- *Color:** White, blue, yellow, green and red.

Installation.

The installation is done by hand, usually with epoxy glue.

- 1.- The surface needs to be dry and clean.
Mark the pavement marker distribution (we recommend every 10 in. in staggered formation).
- 2.- Apply epoxy glue on the back of the pavement marker.
Make sure it's completely covered, especially the corners (approx. 3.5 oz).
- 3.- Put the pavement marker and press it.
It doesn't matter if the glue pours out.
- 5.- Let it dry for approximately 2 h.

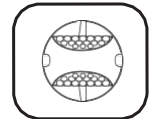
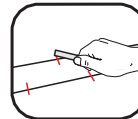

NOTE:

EPOXY GLUE PREPARATION

MIX EQUAL AMOUNTS OF THE "A" AND "B" FORMULAS.

STIR UNTIL THE FORMULAS ARE WELL COMBINED.

SINCE YOU CAN ONLY USE IT ONCE, GET RID OF THE REMAINING EPOXY GLUE ONCE THE JOB IS FINISHED.