

GLASS ROAD STUD 135

Code: BACI ES-135

A leader doesn't follow steps, **he marks the way.**

WHAT'S A GLASS ROAD STUD?

A retroreflective lane marker specially developed to bring safety to the asphalt flooring due to its glass sphere that helps bring higher illumination at great distances day and night.

It can be placed on any type of road since it's perfect for confining and delimiting lanes.

Since it's useful and practical, it doesn't distract the driver but draws their attention due to its reflective sphere.

It's placed over the road surface and is perfect for channeling vehicle traffic, indicating circulation, making drivers reduce their speed, delimiting lanes, etc.

The sphere makes it reflect with car lights which grant it better visibility at night.

Ideal in pedestrian zones, crossings, turnouts, etc.



Features

- Molded with stainless steel in one piece.
- Since the body is filled with silica sand, it has high resistance to hits and impacts and it's inextensible.
- It works perfectly as a speed hump in pedestrian and school crossings or as a lane separator.
- The road stud material is thermal tempered glass which means that in case of rupture, it breaks into small and inoffensive pieces making it 100% safe.
- Its materials and manufacturing methods make it long-lasting.
- It has the option of adding a bolt on the bottom for better fastening on asphalt.
- Since the ABS bolt doesn't break and simply wears out, it doesn't damage tires in case of detachment.
- Easy to install and maintenance-free.
- Usually, its installation needs epoxy glue. This glue is characterized by having high resistance to temperature, physical and chemical agents, and an excellent fastening and long-lasting service life.

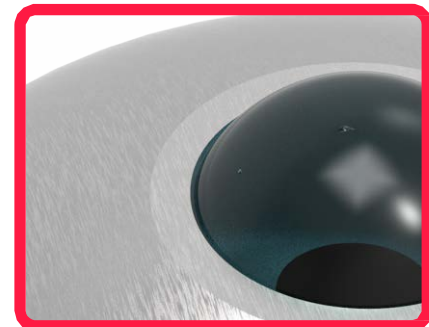

GLASS ROAD STUD 135

Code: BACI ES-135

Volumes, dimensions, and other measures are nominal and may vary by approximately 2%.

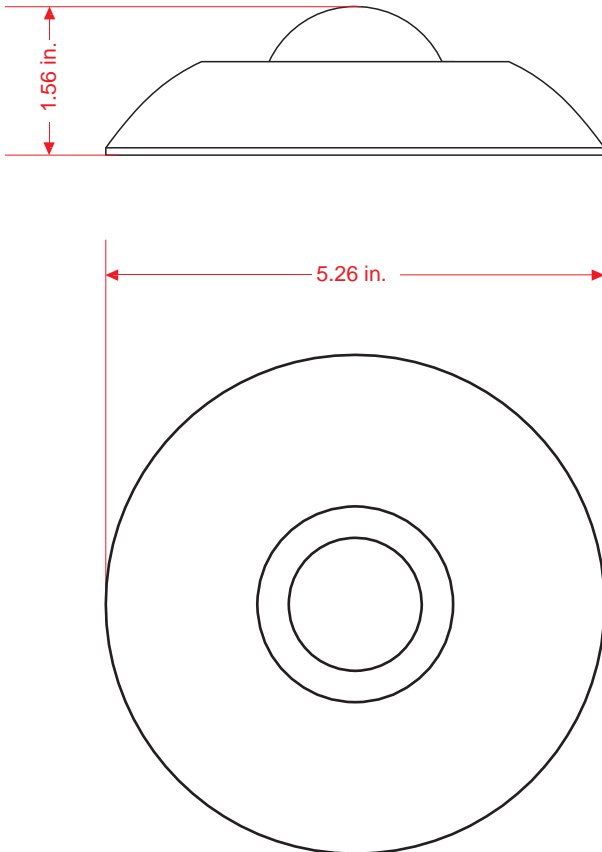

Measures

Road stud	
Material:	430 Stainless steel.
Sheet gauge:	18.
Finish:	2B.
Measures:	Diameter: 5.26 in. Height: 1.56 in.
Approx. weight:	1.21 lb.
Color:	Natural.
Optional bolt:	A36 steel with 3 gaps.
Sphere	
Material:	Thermal tempered silica glass.
Measures:	Diameter 2.06 in. Height: 0.39 in. outside.
Color:	Natural.

Installation.

The installation is done by hand, usually with epoxy glue.

- 1.- The surface needs to be dry and clean.
Mark the road stud distribution (we recommend every 10 in. in staggered formation).
- 2.- Apply epoxy glue on the back of the road stud.
Make sure it's completely covered, especially the corners (approx. 3.5 oz).
- 3.- Put the road stud and press it.
It doesn't matter if the glue pours out.
- 4.- In the case of having a bolt bore into a hole with a 1/2" drill bit to a depth of 3".
Remove the excessive dust and return to step 2.
- 5.- Let it dry for approximately 2 h.

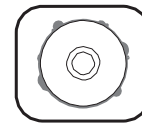
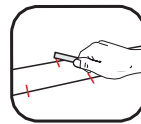

NOTE:

EPOXY GLUE PREPARATION

MIX EQUAL AMOUNTS OF THE "A" AND "B" FORMULAS.

STIR UNTIL THE FORMULAS ARE WELL COMBINED.

SINCE YOU CAN ONLY USE IT ONCE, GET RID OF THE REMAINING EPOXY GLUE ONCE THE JOB IS FINISHED.