

# Plastic Bollards

Code: P81-A / P81-B

Leader don't follow steps  
... marks the way

## WHAT BOLLARDS ARE?

Urban decoration highly resistant and protective with pedestrians and bicycles, works as traffic aligner, as color posts and we have them in different sizes with reflectives.

These elements are good traffic controllers and guaranteed people safety, while manage the accesses in an agile and practic way.

Its recommended to install them in rows along streets and avenues impeding motorized vehicles enter to only walking areas.



## FEATURES

- Classic design bollard idoneous for isolate streets, parks or gardens, etc.
- Excellent combination design and function.
- Made out in medium density polyethylene with reinforced steel skeleton means enough strong item for pedestrian protection.
- Hard resistance to weather harshness including UV rays protection, extreme temperatures and liquids or solvents.
- Just because its material are completely friendly with vehicles, they can't cause important damages, but with the enough strength to deter any collision.
- Colors: granite, antique gray, green, black among others (i.e. sand, antique gold) on demand over 200 pieces.
- Recommended use in parking lots, to delimit security areas, in schools, bus stations. airports, malls, pedestrian passes and else.
- Also can use to regulate traffic flow as in highway toll stations.
- With reflective for better night visibility.
- Easy to install.
- Minimum maintenance.



# Plastic Bollards

Code: P81-A / P81-B

Measures are nominal and can vary,  
between +- 2%.  
All dimensions in inches and onces & lb.

## TOP VIEW

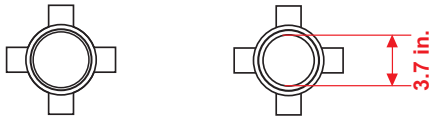

## FRONT VIEW

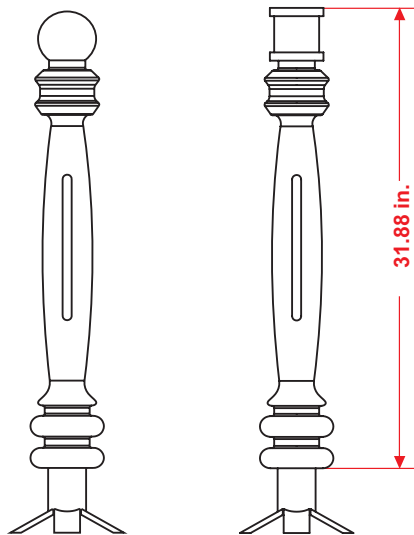

## BOTTOM VIEW

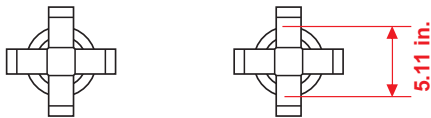

## Measure

<b>Total</b>	Height: 31.88 in. Width: 5.27 in.
<b>Aprox.weight:</b>	24,16 lb.

First mark the auger ubication, then perforate a hole 10 inches diameter and 9 inches depth with a perforating punch. Clear of dirt the hole as possible and pour the cement mix (previously prepared). Insert just the bollard base, check the level (no more, no less) and fill the rest of the hole to get a good cimentation.

