

# DIAMOND-S BARRIER

Code: BDS-174

A leader doesn't follow steps  
... he marks the way



## WHAT'S A DIAMOND BARRIER?

A one-of-a-kind blow-molded safety barrier. It's versatile because it can be filled with water, sand, or use empty. Easy to handle thanks to its exclusive coupling. The cheapest on the market.

The main function of these barriers is to avoid vehicles entering forbidden zones, they are road safety delimiters.

It can be used in rows or curves and contribute to a safer environment.

## Features

- They can delimit, mark and protect work zones and constructions.
- Blow molding in high molecular weight polyethylene.
- Made in one piece for long working life.
- Extreme weather resistant.
- UV protection.
- Better performance in daily rough use.
- It has round corners and edges to avoid injuries.
  
- The diameter of the top lid allows ballasting with tank truck hoses.
- Drain plug on the bottom.
- The modular design integrates a coupling system (male-female) for a strong link between barriers so you can create straight or curved routes.
- A bottom bridge that allows water flow.
- The two engraved bidirectional chevrons with reflective make the barrier visible from anywhere.



# DIAMOND-S BARRIER

Code: BDS-174

Volumes, dimensions, and other measures are nominal and may vary by approximately 2 %.

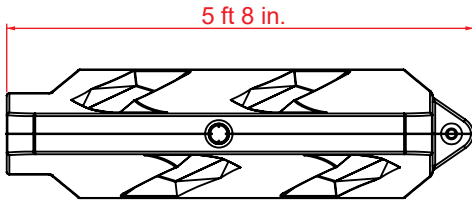

TOP VIEW

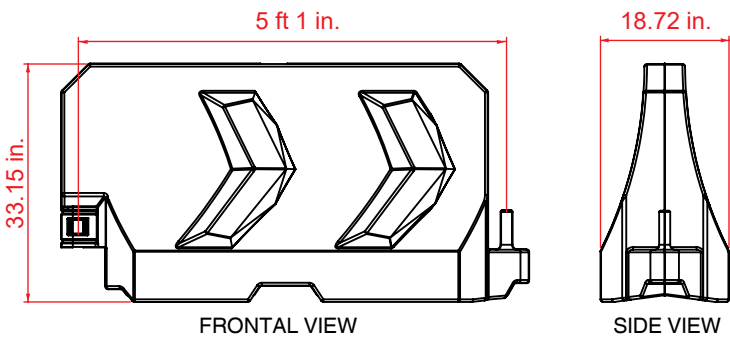

FRONTAL VIEW

SIDE VIEW

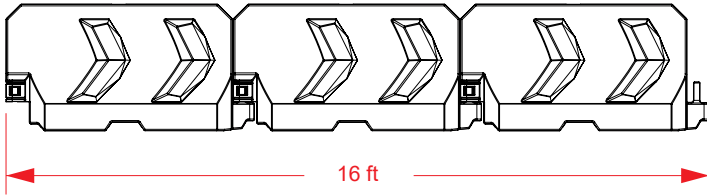

Example of 3 joined barriers

## Measures

### Total

Useful length: 5 ft 1 in.  
Total length: 5 ft 8 in.  
Width: 18.72 in.  
Height: 33.15 in.

### Reflective:

Optional

### Reflective color:

White

