

# PROTECTION BARRIER

Code: B-180

True leaders do not follow  
...they lead the way

## WHAT PURPOSE DOES THE BARRIER SERVE?

Durable road safety barriers designed to endure severe impacts and extreme weather, making them exceptionally durable.

Standalone or in combination, they provide an effective solution for lane guidance, traffic diversion, restricted area protection, and policing support.

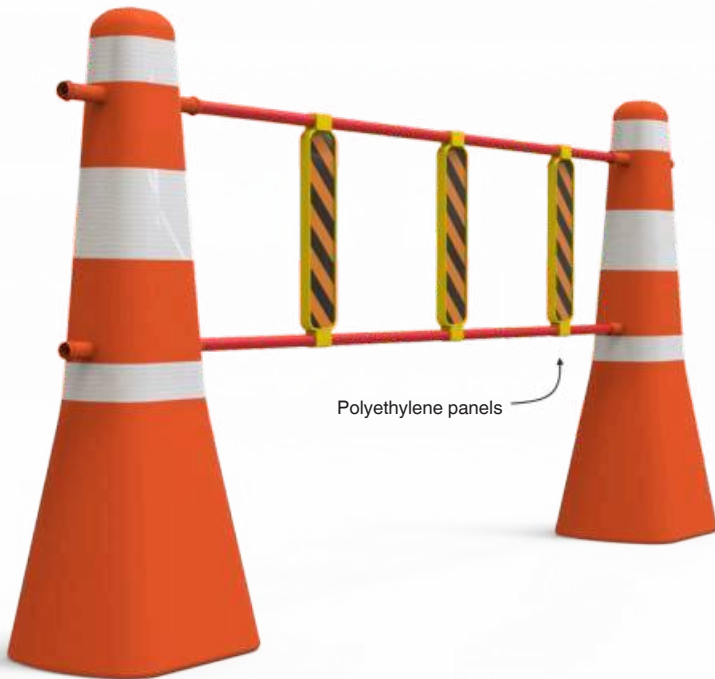

## Features

- Maximizes visibility from any angle.
- Can function individually or as part of a modular barrier system via articulated tubes.
- Optional add-ons include candy-type reflective panels, LED arrow indicators, or custom text banners.
- Featuring three reflective stripes for nighttime safety.
- Requires minimal maintenance.
- Manufactured from one-piece polyethylene; available in blue, orange, or yellow, with other colors on request.
- Smooth, rounded design protects against injury and environmental wear, with UV protection built-in.
- Stability can be increased with water or sand ballast; drainage hole included for convenience.
- High-quality, Ø 1½ in, 18-gauge, 9.84 ft tube for secure barrier joints.
- Allows custom institutional logos.



Vinyl banner with text

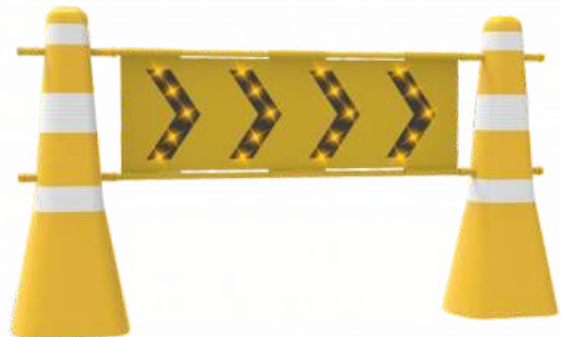

Vinyl banner with chevron pattern and LEDs.

# PROTECTION BARRIER

Code: B-180

Dimensions are nominal  
and may vary by  $\pm 2\%$

Dimensions are in ft

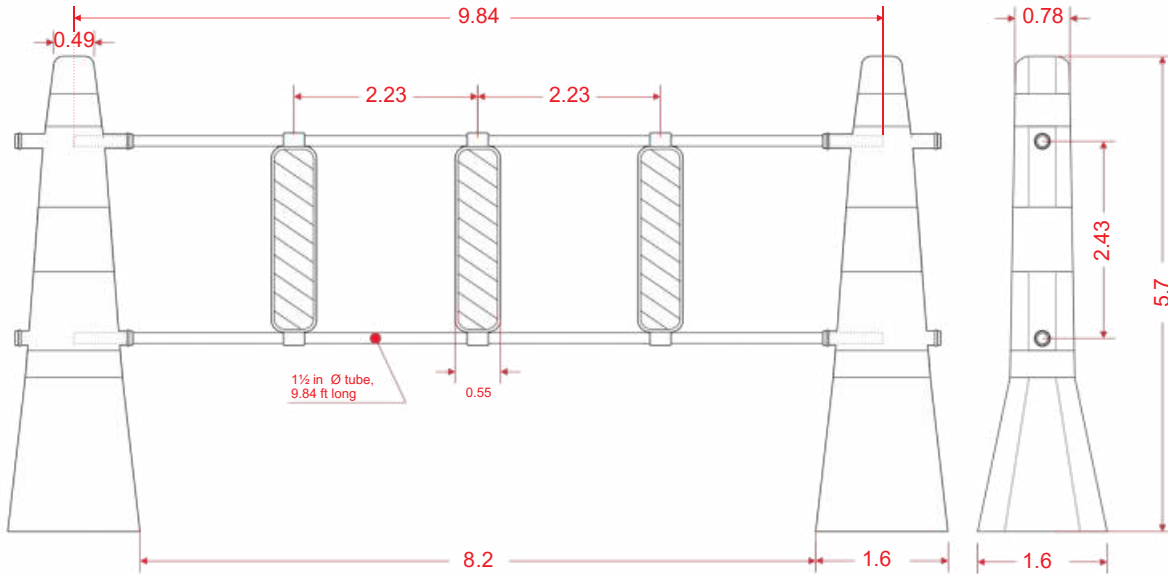

## Dimensions

<b>Complete module:</b>	Length: 11.48 ft
	Width: 1.6 ft
	Height: 5.7 ft
<b>Unit:</b>	Length: 1.6 ft x 1.6 ft, Height: 5.7 ft
<b>Reflective:</b>	Optional
<b>Reflective color:</b>	White

