

# Solar Nestable Barrier Robust 700

Code: BA-RO/700AN-S

## Great savings in storage & transportation!

### UNITY IS STRENGTH

This barrier is an efficient, safe, and affordable tool, perfect to guarantee effective signage.

The perfect barrier to be used in places without street light, and or to guide motorists.

The solar nestable barrier is an innovative and convenient solution for road safety.

Designed to delineate and sign.

It also helps to manage traffic, avoiding accidents and guaranteeing the safety of users.

Ideal to block roads, sign works, separate lanes and detours, as well as delineate sports activities and special events.

Their nestable structure facilitates mounting and detachment, adapting to different situations quickly.



### Features

- Designed with a modular system of easy installation, this barrier offers an innovative, exclusive, and highly functional solution for road signage and traffic control projects.
- Thanks to the nestable design allows for a reduction of 75% in storage and transportation costs, becoming an affordable, convenient, and efficient option.
- It can easily adjust to different lengths according to the specific needs of the project or event.
- Manufactured in white high-density polyethylene with UV protection, guaranteeing a long lifespan and excellent performance before extreme weather conditions.
- Body engraved with two chevrons per face to add reflective sheeting (optional), increasing night visibility.
- Fast and safe installation of male-female system; suitable for assembly by one person with minimal effort. Perfect for wind flow, decreasing tilting.
- For greater stability, add a stabilizing weight to improve performance before strong wind gusts.

### Intelligent Solar Lighting

- Equipped with ultrabright, latest-generation LEDs, it can incorporate one or two solar cells of high efficiency for excellent light scattering.
- Batteries recharge for 6 hours and last 16 continuous hours.
- Includes JVM circuit for high reliability, with the ability to synchronize with multiple barriers for a uniform visual effect, improving safety in low light conditions.



ENGRAVED CHEVRONS  
IN BODY



HANDLE

HANDLE TO  
MANAGE



SAFE COUPLING



Light

SOLAR CELL

# Solar Nestable Barrier Robust 700

Code: BA-RO/700AN-S

*Dimensions and other measures are nominal and may vary by  $\pm 2\%$ .*

Dimensions in: in

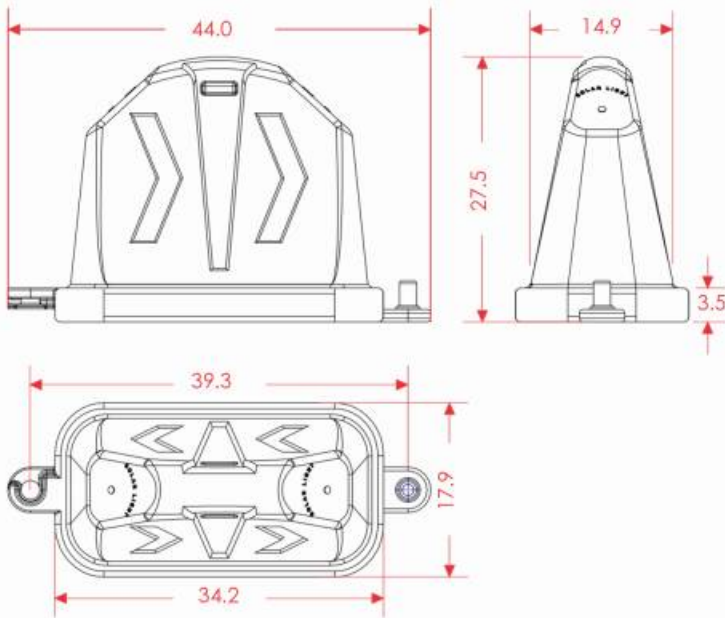

## Measures

**Total** Total length: 44.0 in  
Width: 17.9 in  
Height: 27.5 in

**Color of Reflector:** Orange

**Weight of barrier (without base):** 7.716 lbs

	barrier+S base	barrier+S base+1 light	barrier+S base+2 lights
<b>Small base barrier</b>			
	18,077 lbs	18,739 lbs	19,400 lbs



53-ft dry van with capacity for approximately 1,300 nestable barriers, covering up to 4,518 linear feet of channelization

