

# Blowed Mini Barrier

Code: RS-100

Leader don't follow steps  
... marks the way

## WHAT IS THE RS-100 BARRIER?

Barriers are traffic equipment that provides safety to vehicles and people that pass by a works zone or a forbidden area.

Marks limits between one zone and another, signalise and protect any kind of road works, send vehicles and people to a less risk room.

Ideal as a limiter and for traffic channelizing in every avenue, street, road and else.



## FEATURES

- A light-weight product to easy carry where traffic channeling is needed urgently.
  - Its modern structure design has a lot of valuable operative benefits.
  - Seven cavities "light-catchers" at each side with reflectives to make safer roads for drivers; Also with two chevrons that indicate traffic orientation and a horizontal bright strip along its body, 4 reflectives in the light-catchers with special angle for enhanced visibility.
  - Made out in high resistant polyethylene
  - One piece body guarantees durability with no rips.
  - Orange is line color, other aspect on demand.
  - Extreme temperature changes and UV rays resistant.
  - For increase weight, stability and containment level can be filled with sand balast trough its upper valve. Also has a drain valve on below. Or can be filled with water too.
  - With a strong coupling system (male-female) creates a perfect continued barrier as long and extensive as your needs, and also the barrier can be opened at any moment for a selective pass thru.
  - The barrier design has an arch on its bottom to allow a water current pass and avoid being trail.
- *Note: The lateral light-catcher are under registration in the IMPI.*



Angled "light-catcher"



Bi-directional chevrons

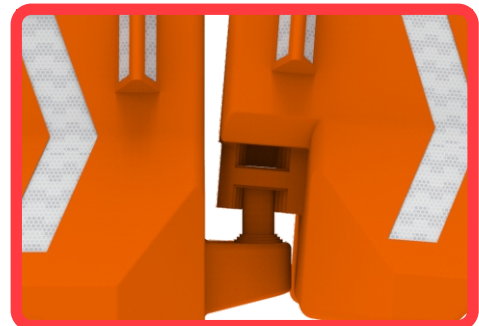

Coupling System  
(male-female)

# Blowed Mini Barrier

Code: RS-100

Measures are nominal  
and can vary,  
between +/- 2%.

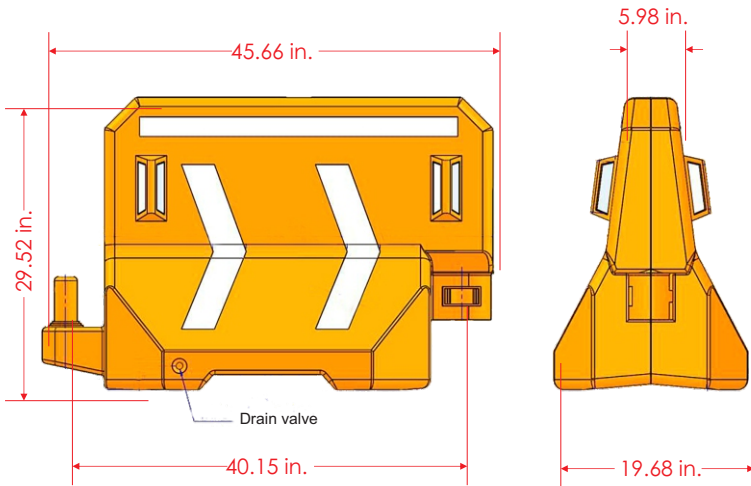

## Measure

<b>Total</b>	Effective length: 40.15 in. Width: 19.68 in. Height: 29.52 in. Total length: 45.66 in.
<b>Reflective:</b>	7 zones by side
<b>Reflective color:</b>	White



*Images and graphics are illustrative*