

REX AIRPORT BARRICADE

Code: BA-REX



WHAT IS THE REX BARRICADE?

- This impact-resistant barricade is designed to divide lanes, to block off restricted areas, or separate traffic flows.
- Features a male-female assembly system for secure installation.
- Creates a clear exclusion zone, enhancing safety by guiding pedestrians and drivers safely around hazardous areas.
- Can be equipped with traffic flags or a solar-powered strobe beacon for increased visibility and effectiveness.

Features

- Manufactured from high-resistance polymer in orange, this barrier ensures durability and visibility.
- Optional reflective panels on both sides improve safety in low-light conditions.
- Stackable design lowers transport and storage costs.
- **Fill/drain cap** allows ballast with water or sand to enhance stability, and can be handled with a forklift.
- **Up to 2 traffic flags** and 2 solar-powered strobe beacons, or a combination (with red polycarbonate housing with black ABS base, high impact resistance and hardness, automatic ON/OFF operation at dusk for **energy savings**).
- **8 red LEDs** fixed with screws.
- **Fluorescent orange sport mesh flag** with silver reflective edging, equipped with yellow fluorescent prismatic reflectors on both faces to maximize nighttime visibility.



Male-female assembly



Boreholes for one or two traffic flags



Traffic flag and solar-powered strobe beacons



Solar-powered strobe beacon

REX AIRPORT BARRICADE

Code: BA-REX

Dimensions and other measurements are nominal and may vary by $\pm 2\%$

Dimensions are in **inches and feet**

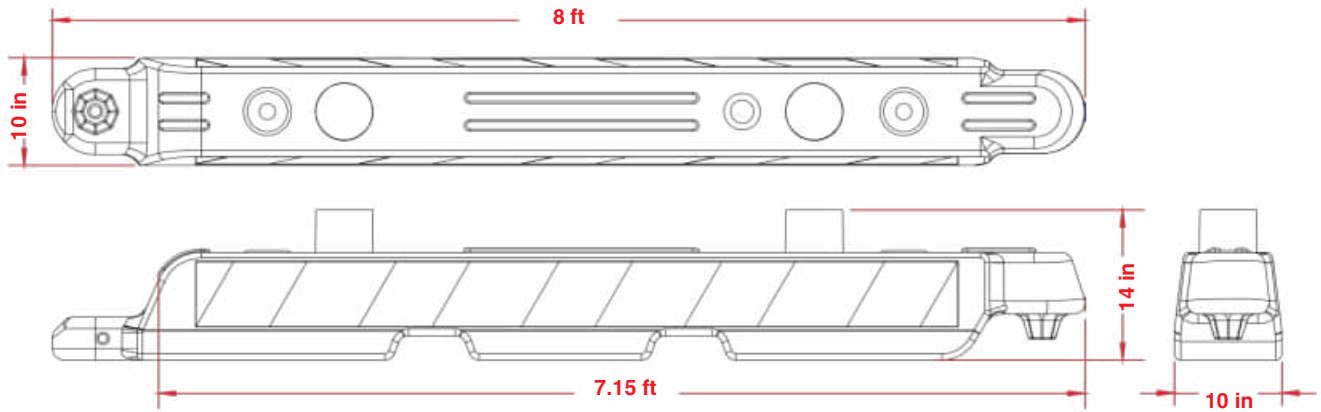

Dimensions

Dimensions:	Length: 8 ft Width: 10 in Height: 14 in
Reflective elements:	Barricades with side reflective elements can be either directional or bidirectional.
Reflective color:	White

