

A leader doesn't follow...
marks the road



WHAT'S A PERRY BARRIER?

Road safety barrier, unique in its type, versatile due can perfectly confine in linear or curved way; easy to manage thanks to exclusive coupling.

Great use to delimit, sign and provide safety in work zones and constructions.

Its use is suggested in rows or curves, contributing to a safer environment.

Features

- Guides transit to the indicated lane.
- The design of its body offers better performance, structural resistance and long life span.
- Extraordinary stability and firmness in body.
- Manufactured in a single piece of medium density polyethylene even thickness of walls with edges and round borders, in case of impact avoids injuries.
- Line color: orange and yellow.
- Long shelf life; resistant to inclemency and temperature changes with UV protection.
- Maximum versatility, due can be filled with water, sand or can be used empty. It is recommended to fill it up to 60% of its capacity.
- Base with 2 arcs that facilitate the water flow, also used for forklifts.
- Each of their faces has 2 engraved directional or bidirectional chevrons (diamond type) to sign the vehicular transit.
- In addition, has reflective tape for a better night visibility (optional).
- Male-female assembly system to create curved and straight rows.
- Its easy, quick and safe join can be performed by one person with a minimum effort.
- Comply with the standard established by SETRAVI (Secretary of Transport and Road).

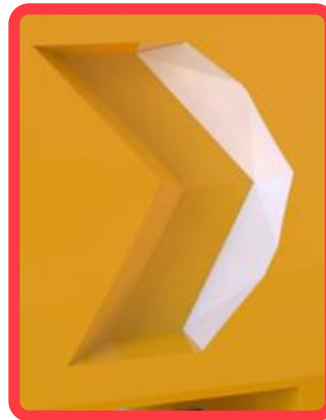

PERRY BARRIER

Code: BA-1500

Dimensions and other measures are nominal and may vary by +/- 2%.

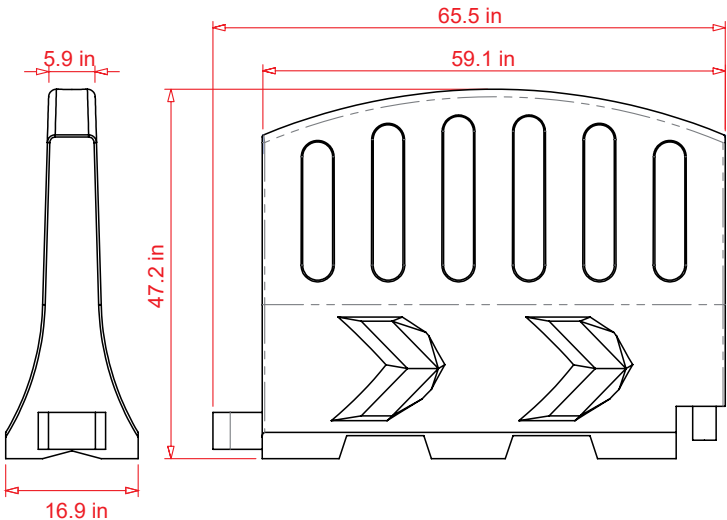

Measures

Total	Total Length: 65.5 in Length: 59.0 in Width: 16.9 in Height: 47.2 in
Reflective sheeting:	2 chevrons, per side
Reflective sheeting color:	White.
Weight (empty):	39.6 lbs.
Filling Capacity:	330 lt or kg/727.5 lbs or 87.1 gal.

