

# S81 BARRIER

Code: B-S81

A leader doesn't follow  
... marks the way

## WHAT'S THE S-81 BARRIER?

Traffic safety barrier with new assembly system, versatile device that perfectly confine curves; easy to more thanks to its lightweight.

Its main function is cordon off prohibited zones; also used to delineate roads safely.

Mainly suggested in line, square, triangle or the most convenient way for you, contributing to a safer environment.



## Features

- Useful to delimit and sign, providing safety due allow to cover greater distances and reach the desired length.
- Guide road transit to an indicated place, thanks to the join among barriers.
- Lower bridge for water flow or being lift by forklift.
- 2 center ovals to allow the air passage and avoid falls.
- Manufactured in High Molecular Weight Polyethylene.
- Long life span, resistance to environment inclemency and temperature changes with UV protection.
- Line color, orange. More colors upon request.
- Lightweight with stability and firmness.
- Option to increase weight and strength, filling with sand or water; top cap included. It is recommended to fill to a 30% of the device for an optimal functioning and stability; with drainage cap.
- Male-female assembly system, easy, fast, safe join, able to perform by one person with a minimum effort.
- Reflective sheeting on sides increase visibility during night (optional).
- In addition, includes 5 engraved chevrons on body per face; can include reflective sheeting indicating the direction of circulation.
- Assembly registered by IMPI.

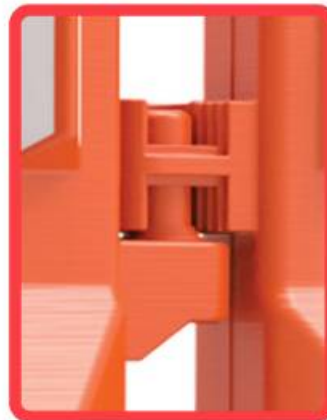

# S81 BARRIER

Code: B-S81

Dimensions and other measures are nominal and may vary by +/- 2%.

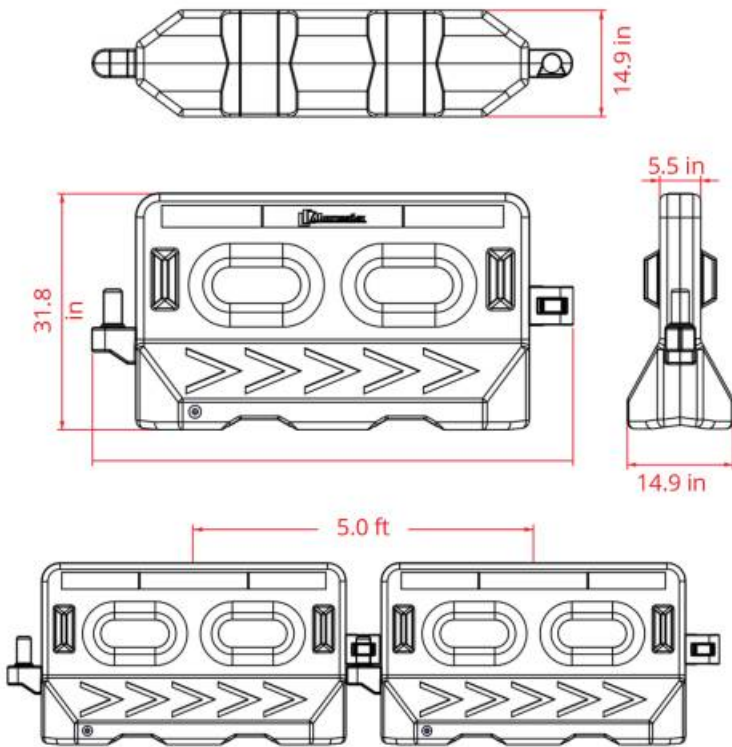

## Measurements

<b>Total</b>	Functional Length: 5.0 ft Length: 5.4 ft Width: 14.9 in Height: 31.8 in
<b>Reflective sheeting:</b>	Chevron
<b>Color of reflective sheeting:</b>	White

