

BRIO-1000 PLUS TRAFFIC BOLLARD

Code: BBRIO-1000 PLUS



Leader don't follow steps
... marks the way



- "Ultrafix" screw hexagonal head
21 v Ø 3/8" x 5.9 in. - "Extralarge"
tacket
Ø 0.7 x 5.31 in.

Features

- These traffic bollards are 100% flexibles so it can be use with confidence with any risk.
- Returns to its original position in case of multiples run-ins or collision with cars.
- Manufactured in a new generation plastic material that enhanced its desirable properties, it can support until 5,000 run ins with a force less than 5 tons.
- Design and made it in one piece plastic without assembled parts for a guaranteed resistance.
- These new traffic bollard are composed in POLIFLEXY PLUS®; a exclusive material flexible and resistant.
- The post is well bonded with the base to make a unique body so difficult to detach.
- Integrated color: black
- 2 prismatic reflective material rings along the post for a better visibility in dark.
- Fixed to floor with an anchorage of 4 steel screws and extralarge tackets.

WHAT IS A TRAFFIC BOLLARD?

A Traffic Bollard is a signalise mark post used to indicate risk zones or closed.

HOW A TRAFFIC BOLLARD WORKS?

Its main function is avoid vehicles to invade pedestrian zones, risk areas o protected bicycle lanes. Are traffic limiters for get more safety parking lots and else, also distribute the streets and avenues room in case of emergency or can create a only pedestrian lanes.

RECOMMENDED USES

Avoid automotors to invade risk zones, work or restricted areas also as a warning signal in case of any danger or situation on-road.



BRIO-1000 PLUS TRAFFIC BOLLARD

Code: BBRIO-1000 PLUS

Measures are nominal and can vary, between +/- 2%.

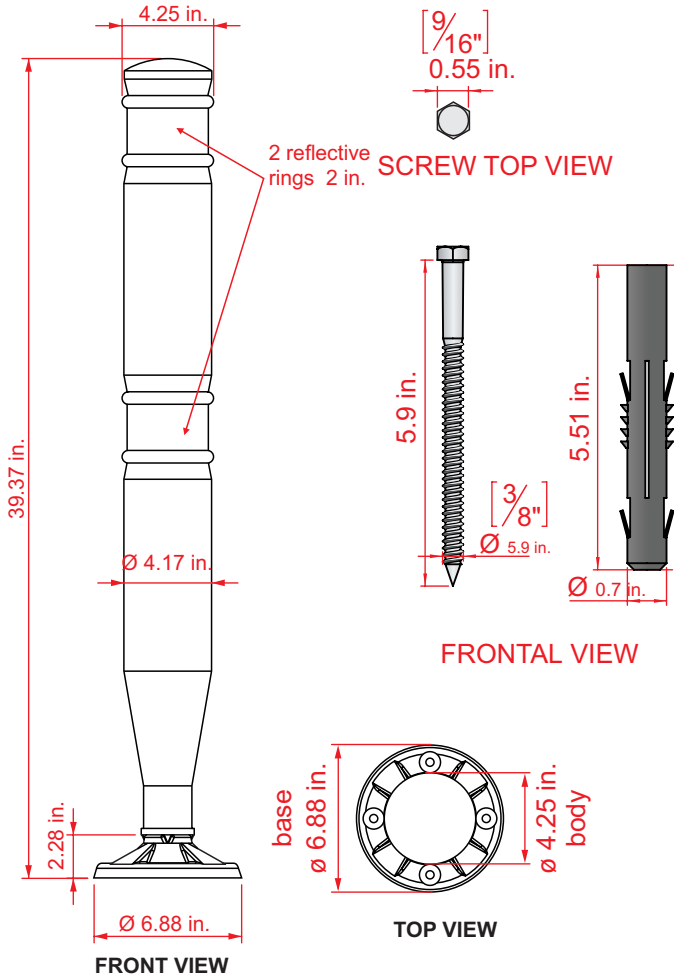

Measure

Total	Height: 39.37 in. Ø sup. 4.25 in. Ø base 6.88 in
Reflective:	2 rings of 13.03 sqr in.
Reflective Color:	white or amber.
Weight:	39,85 oz.

Anchor to floor

Mark the four holes on ground for the bollard's base. Then perforate with a 3/4" drill bit down to a 7" depth. Once the holes are correct introduce the tackets and place the bollard put the screws with the 3/8" plane washers. Time to wrist them with a 9/16" cube and your traffic bollard its ready on its site.

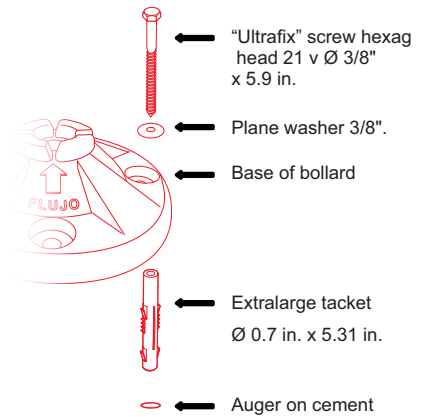

**long life service
 more resistance
 lower price**