

SUJE-1 WALL MOUNT BRACKET



DESCRIPTION

The material of the **SUJE-1 WALL MOUNT BRACKET** is galvanized steel which gathers high resistance and avoids deformations. It's designed for the **PC-1 Sharps Container** and the **PL-1 Liquid Waste Disposal Container**.

- It has two boreholes to screw to the wall.

FUNCTIONALITY

Designed to place the **PC-1** and the **PL-1** on the wall.

Useful for moving and collecting residues without grabbing them for its transportation. It prevents the user has direct contact with any residue.

FEATURES

MEASURES:

Length: 3.9 in.
Width: 3.15 in.
Height: 4.25 in.

THICKNESS: 1 mm

WEIGHT: 2.1 oz.

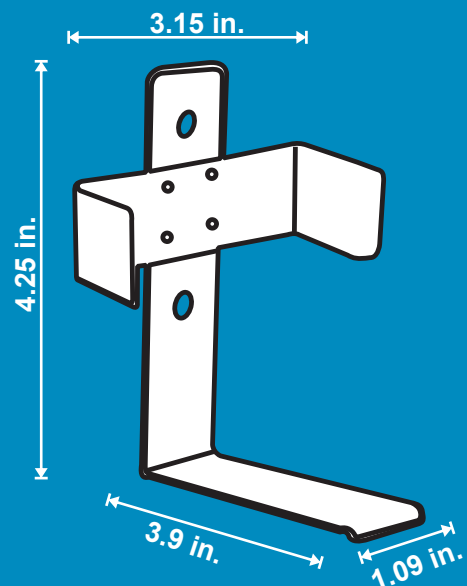

Dimensions and other measurements are nominal and may vary by $\pm 2\%$



SUITABLE FOR HEALTHCARE SETTINGS

