

GIANT STACK CONTAINER



CUSTOMIZATION

According to your needs, it can be labeled with your logo or the caption of the type of material it contains.

DESCRIPTION

The material of the **GIANT STACK CONTAINER** is medium-density polyethylene which gathers the highest fluidity conditions and the highest resistance to hits and breaks.

- It has handles on both sides for a better transfer.
- It has reinforcements on the sides to withstand stacking.
- A front opening to prevent putting large waste.
- Smooth walls.
- UV protection.
- Highly resistant to weather conditions.
- An optional polyethylene lid.

FUNCTIONALITY

The **GIANT STACK CONTAINER** is perfect for recycling. Its stackable feature makes it ideal for keeping any objects organized and uses less space.

- Easy to clean.
- Avoids sources of infection.

FEATURES

CAPACITY: 49 L (12.93 US gal)

COLORS: Green, red, yellow, gray, blue, and beige.

MEASURES:

Length: 20.55 in.

Width: 14.82 in.

Height: 12.09 in.

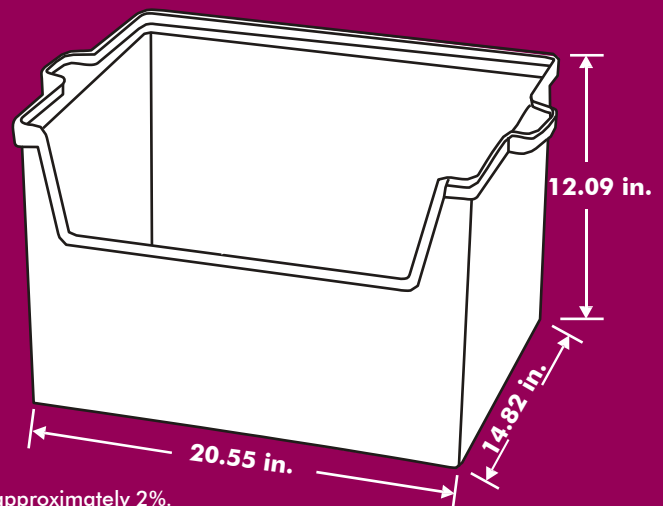

Volumes, dimensions, and other measures are nominal and may vary by approximately 2%.