

# ECOL EC1 RECYCLING STATION

CODE: ECOL-240-EC1 / 360-EC1

## DESCRIPTION

The ECOL EC1 Recycling Station enhances waste separation with an organized, attractive, and practical configuration. A modular arrangement features VIC 31.7-gal containers manufactured from high-strength polymer, designed for outdoor installation and demanding, high-traffic settings.

A heavy-duty galvanized steel structure with resistant coatings delivers reliability in public or commercial spaces. Multiple configurations allow installation with 2, 3, or 4 containers based on available space and collection needs.



**Ecol-240-EC1**



**Ecol-360-EC1**



Resists sudden temperature changes



Recyclable, sustainable materials







For outdoor installation

## FEATURES





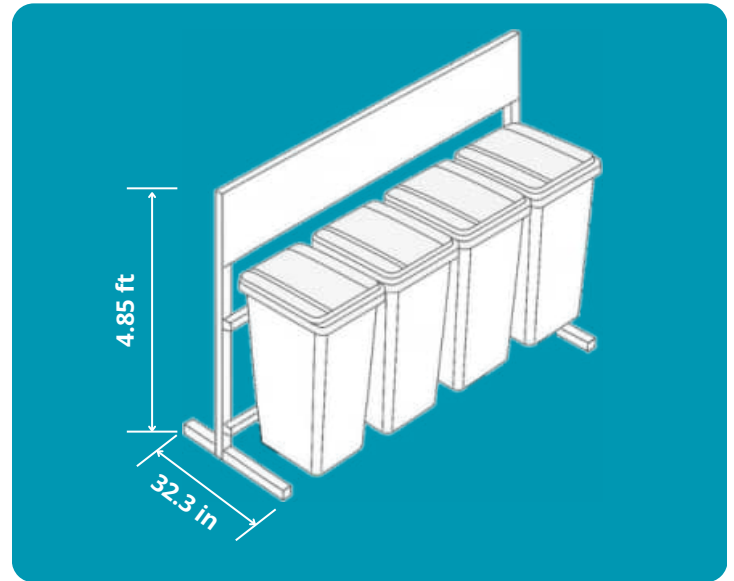

- Includes VIC 120L containers (up to 4 units)
- Smooth interior with rounded corners
- Anti-vandal system with security pin and dedicated key
- Structure built from 2" x 2" and 2" x 1" rectangular steel tube
- 18-gauge galvanized steel sheet in the advertising area
- Low investment and maintenance cost
- UV protection

## DIMENSIONS

 Length (Variable according to the number of waste bins)	3.6 - 7.2 ft
 Width	32.3 in
 Height	4.85 ft
 Capacity	63.4, 95.1 or 126.8 gal



Container color classification:

 <b>Organics</b>	 <b>Non organics</b>
 <b>Plastics</b>	 <b>Mixed waste</b>
 <b>BIHW</b>	 <b>Recyclable materials</b>

## DESIGN & USE

- Easy installation with low maintenance requirements
- Clean, functional design suited for urban environments
- Well-suited for environmental campaigns and waste separation in public areas

Make waste management  
simpler and safer

**ECOL EC1  
RECYCLING  
STATION**