

VIC 1100 HD PEDAL FOOT-OPERATED BIOHAZARD CANISTER

CODE: VIC-1100-HD

DESCRIPTION

Designed to meet the highest standards of hygiene and structural strength required for waste handling in healthcare environments.

A concave lid prevents water accumulation, supporting infection control and odor reduction. The unit features a foot-operated opening system for hygienic access and four 8-inch swivel casters, with two front brakes to support controlled and secure movement. Ergonomic side handles facilitate manual transport, along with lateral mechanisms compatible with automatic lifting systems on collection trucks.

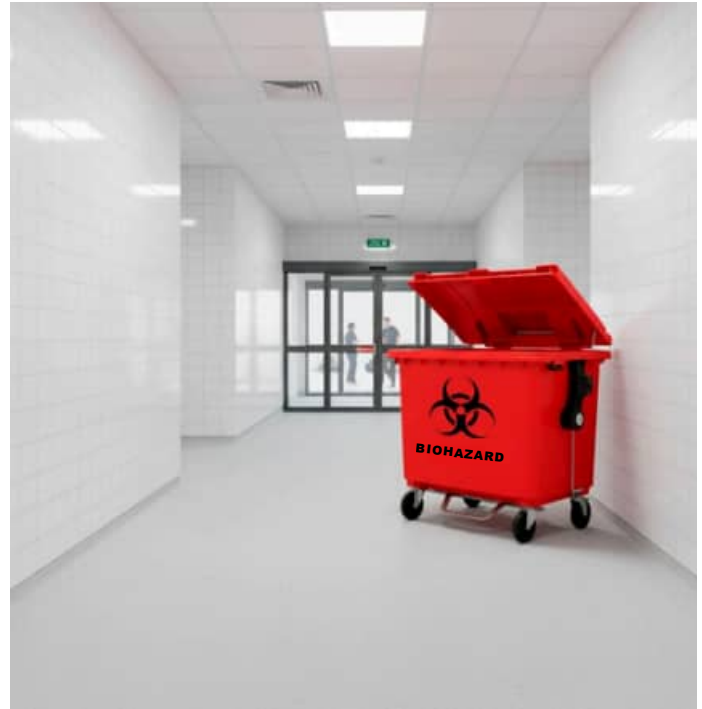

FEATURES

- Manufactured from high-strength polymer, delivering strong resistance to impacts, chemical exposure, and adverse weather conditions
- A design that prevents water accumulation limits the growth of bacteria, mosquitoes, and unpleasant odors
- A foot-operated opening system enables lid access without manual contact, supporting hygienic and safe handling
- Two ergonomic handles support manual transport of the container, combined with two lateral attachment points designed for lifting systems



Biological
waste only







Hazardous
waste only



Sharp object
protection

DIMENSIONS

 Length	54 in
 Width	42.5 in
 Height	54.3 in
 Weight	112.4 lb
 Capacity	290.6 gal

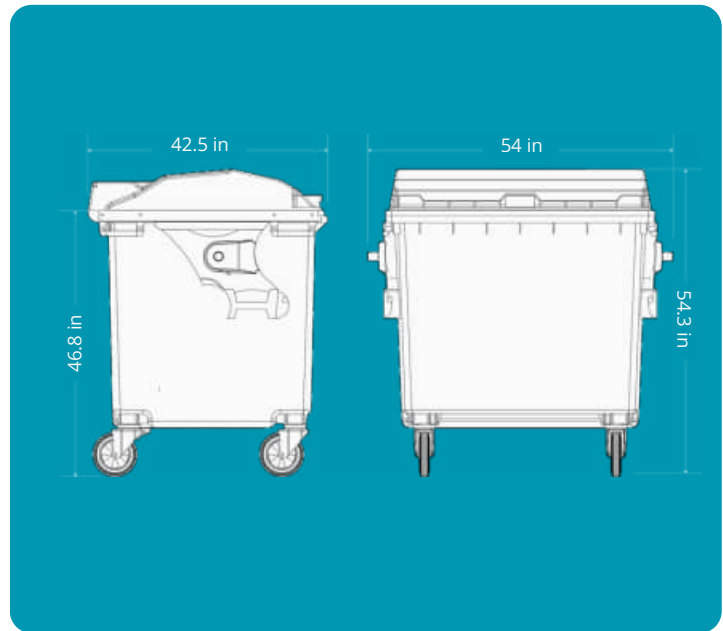

DESIGN & USE

- Designed for integration with automatic lifting mechanisms on waste collection vehicles, contributing to efficient collection cycles, lower operational effort, and reduced occupational risk
- High-strength canister wheels combined with ergonomically placed handles allow easy maneuverability across hallways, ramps, and clinical areas, even when fully loaded
- Beyond healthcare applications, this container performs effectively in industrial settings that demand a robust and hygienic approach to waste handling

AVAILABLE COLORS

 gr Organic waste	 bl Plastic waste
 gra Non-recyclable waste	 re Biohazardous waste
 ye Sanitary & medical waste	 or Bottles, containers

Reliable safety in
hazardous waste handling!

VIC 1100 HD PEDAL FOOT-OPERATED BIOHAZARD CANISTER