

VIC 240 HD TRASH CAN

CODE: VIC-240-HD

DESCRIPTION

The **VIC 240 HD Trash Can** is a robust and ergonomic system designed for waste handling in healthcare environments. Manufactured from high-strength polymer through an injection molding process, the structure is formed as a single seamless piece without rivets, enhancing structural strength and eliminating stress or fracture points. The functional design includes a mechanical pedal-operated lid, dual handles to support emptying operations, and a smooth interior with rounded corners that helps prevent residue buildup and supports efficient cleaning.



FEATURES

- The container body is manufactured as a single piece through injection molding, supporting consistent structural performance
- Two 8-inch PVC wheels mounted on a single axle enable smooth, stable, and secure container movement
- A pedal-operated mechanism delivers stability, wear resistance, and reliable operation in high-frequency environments
- Two reinforced side handles allow secure grip, controlled emptying, and easy transport
- The design supports stacking when empty, significantly reducing space requirements during transportation and storage, with clear logistical and operational efficiency benefits



Biological
waste only







Hazardous
waste only



Manual
container
transport

DIMENSIONS

 Length	28.7 in
 Width	22.8 in
 Height	41.7 in
 Weight	30.8 lb
 Capacity	63.4 gal

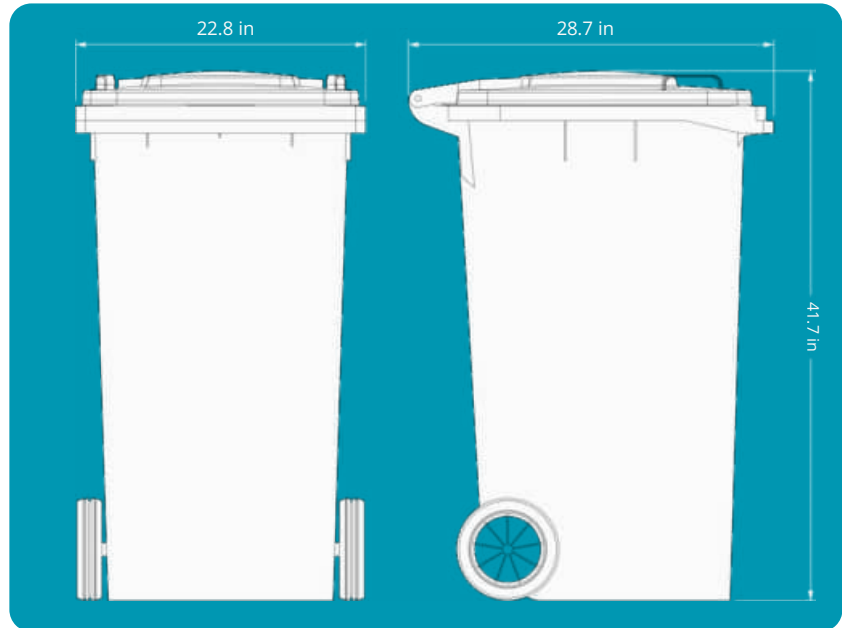

AVAILABLE COLORS



DESIGN & USE

- Safe, contact-free collection of hazardous waste through a pedal-operated opening mechanism
- Easy cleaning and sanitization supported by a smooth interior surface without internal joints
- Agile and secure transport enabled by durable wheels, suitable for circulation across clinical areas or outdoor routes
- Complies with biosecurity protocols for hazardous waste handling in medical facilities

Risk-free environment

**VIC 240 HD
TRASH CAN**