

SUJE-2C WALL MOUNT BRACKET



DESCRIPTION

The material of the **WALL MOUNT BRACKET SUJE-2C** is steel, and it's a basket designed for the **Sharps Container PC-2**.

- It has corrosion protection with powder coating.

FUNCTIONALITY

This basket is designed to place the **Sharps Container PC-2** on the wall.

Useful for moving and collecting residues without grabbing them for its transportation. It prevents the user has direct contact with any residue.

FEATURES

COLOR: White

MEASURES:

Length: 5.96 in.

Width: 5.96 in.

Height: 4.75 in.

WEIGHT: 5.42 oz.

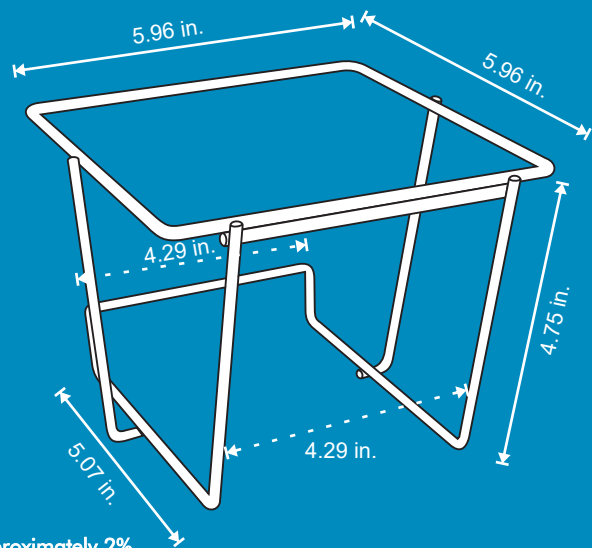

Volumes, dimensions, and other measures are nominal and may vary by approximately 2%.



PERFECT FOR MEDICAL AREAS

