

PC-1N SHARPS AND BIOHAZARD WASTE CONTAINER

CODE: PC-1N

DESCRIPTION

Safely collects and disposes of contaminated liquids, sharps, and hazardous materials in healthcare environments.

Protects against punctures and accidents, keeping needles and sharp items secure.

Bright red color and airtight lid enable easy identification and safe handling.

Perfect for hospitals, clinics, and labs, helping maintain a safe, compliant environment.

Engineered for controlled incineration, with a chlorine-free, low-heavy-metal composition that minimizes emissions for environmentally responsible disposal.



FEATURES

- Perfect for needles and sharps, specifically designed for medical and hazardous waste
- Compliant with health regulations, ensuring proper handling of infectious waste
- Prevents accidents with a design that keeps needles and sharp objects securely contained
- Non-slip base provides stability, preventing tipping during use
- Suitable for multiple settings, including hospitals, clinics, laboratories, and any facility generating sharps waste



Complies with
**NOM-087-SEMARNAT-2002
STANDARD**



Biological
waste only



Hazardous
waste only





Sharp object
protection





Controlled
incineration



DIMENSIONS

 Length	4.1 in
 Width	4.1 in
 Height	6.1 in
 Weight	3.4 oz
 Capacity	0.26 gal

MATERIAL COMPOSITION

 Chlorine-free	
 Total heavy-metal content: ≤ 1 ppm	

DESIGN & USE

- The **PC-1N Sharps and Biohazard Waste Container** is designed to ensure the safe collection and disposal of sharps, including needles, syringes, and other hazardous objects in medical environments
- Durable construction prevents punctures, helping protect workers from potential accidents
- Ideal for compliance with health regulations, providing safety and efficiency in the handling of hazardous medical waste

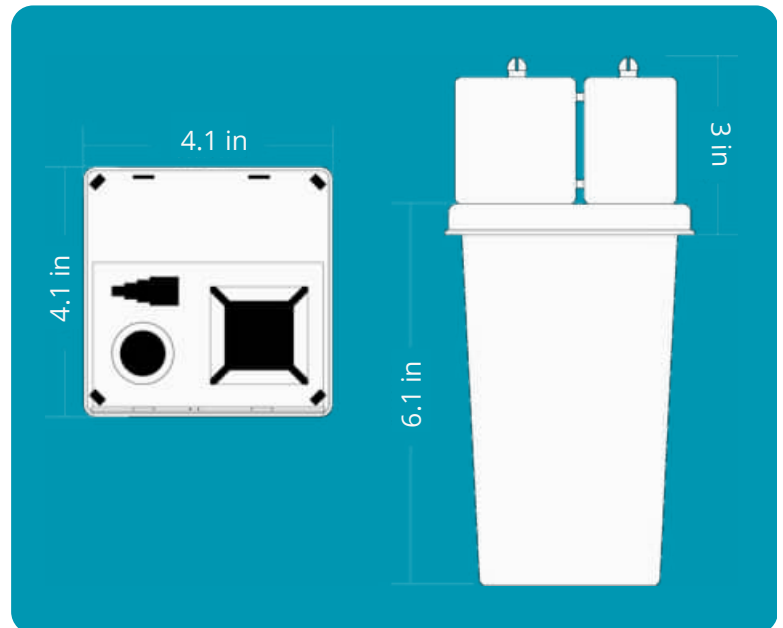

Keep your team
safe and protected

PC-1N SHARPS AND BIOHAZARD WASTE CONTAINER