

BELMONT STRAIGHT BENCH

CODE: BAN-BE-R

DESCRIPTION

The Belmont Straight Bench provides a contemporary, functional, and stylish solution for urban environments. Manufactured from high-strength polymer, it ensures exceptional resistance to frequent use, impact, vandalism, and prolonged UV exposure. This ergonomic modular design seats up to four users and supports versatile combinations in a wide range of public or private settings.

Equipped with internal lighting and optional features including Bluetooth sound and mobile-device charging, the bench enhances any space with comfort, safety, and modern innovation.



FEATURES

- Manufactured from high-strength polymer
- Durable against impacts, ultraviolet exposure, and vandalism
- Straight modular layout with curved frame design
- Accommodates up to 4 users
- Optional technological features:
 - Bluetooth audio
 - Mobile phone connection
 - Built-in internal lighting
- Customizable with corporate or institutional logos
- Quick and secure installation with stable base





Weather-change resistant



Built-in reabsorption mechanism

DIMENSIONS

 Length	82.2 in
 Width	26 in
 Height	42.1 in

DESIGN & USE

- Provides comfortable and safe seating for users in public and private spaces
- Supports modular combinations to adapt to surrounding designs
- Maintains a clean, modern appearance with anti-graffiti coating
- Delivers decorative and functional nighttime illumination
- Serves as an interactive gathering point with audio and connectivity features
- Promotes corporate identity in public spaces through logo integration
- Contributes to the modernization and enhancement of aesthetics of urban furniture

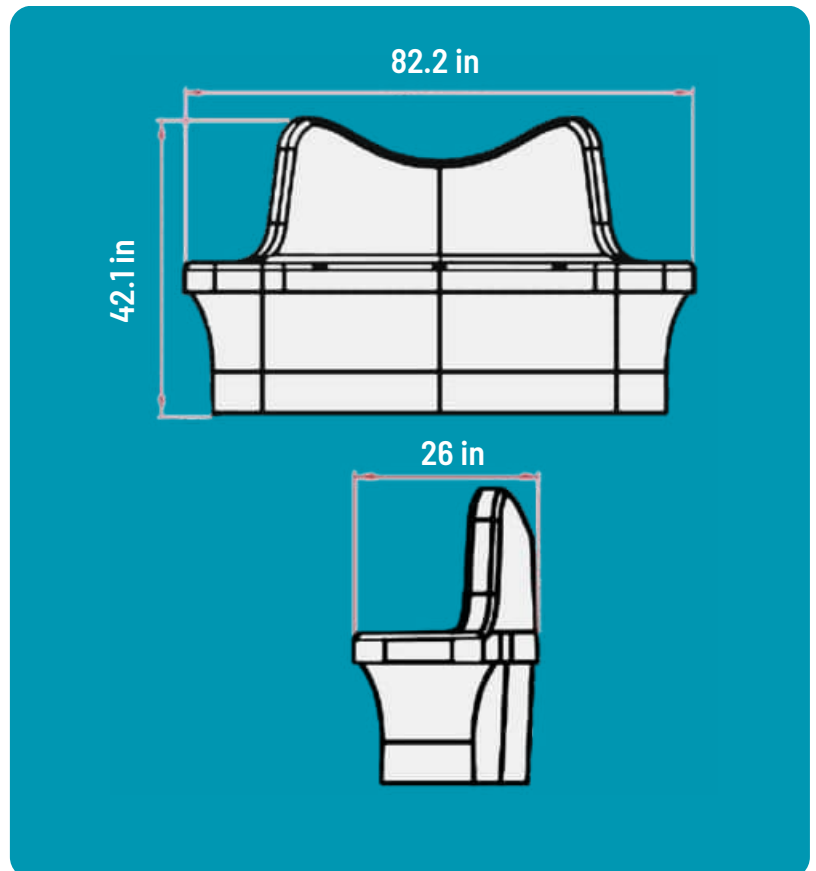

Examples of versatile configurations are:

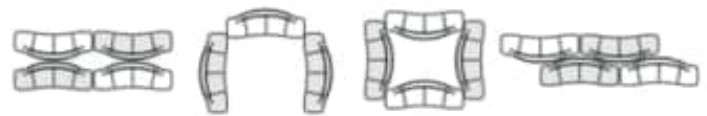

Comfort and durability
for any setting

**BELMONT
STRAIGHT BENCH**